



1

Hydraulic Structure I – CENG 3161

Chapter 4. Hydraulic Structures In Hydro Power Stations

Instructor: Yayneshet W.
yaniw2721@gmail.com

4.1 Introduction

- Hydropower engineering refers to the technology involved in converting the pressure energy and kinetic energy of water into more easily used electrical energy.
- The electrical energy is obtained from the generators coupled to water turbines which convert the hydraulic energy in to mechanical energy. This means ;
- The mechanical energy is produced by running a prime mover (turbine) from the energy of flowing water.
- This mechanical energy is converted to electric power by generators which is directly coupled to the shaft of the turbine.

Cont....

- The plant or machinery which is required to produce electricity (i.e. prime mover or turbine + electric generator) is collectively known as the power plant.
- The building , in which the entire machinery along with other auxiliary units is installed, is known as the power house.

Cont....

4

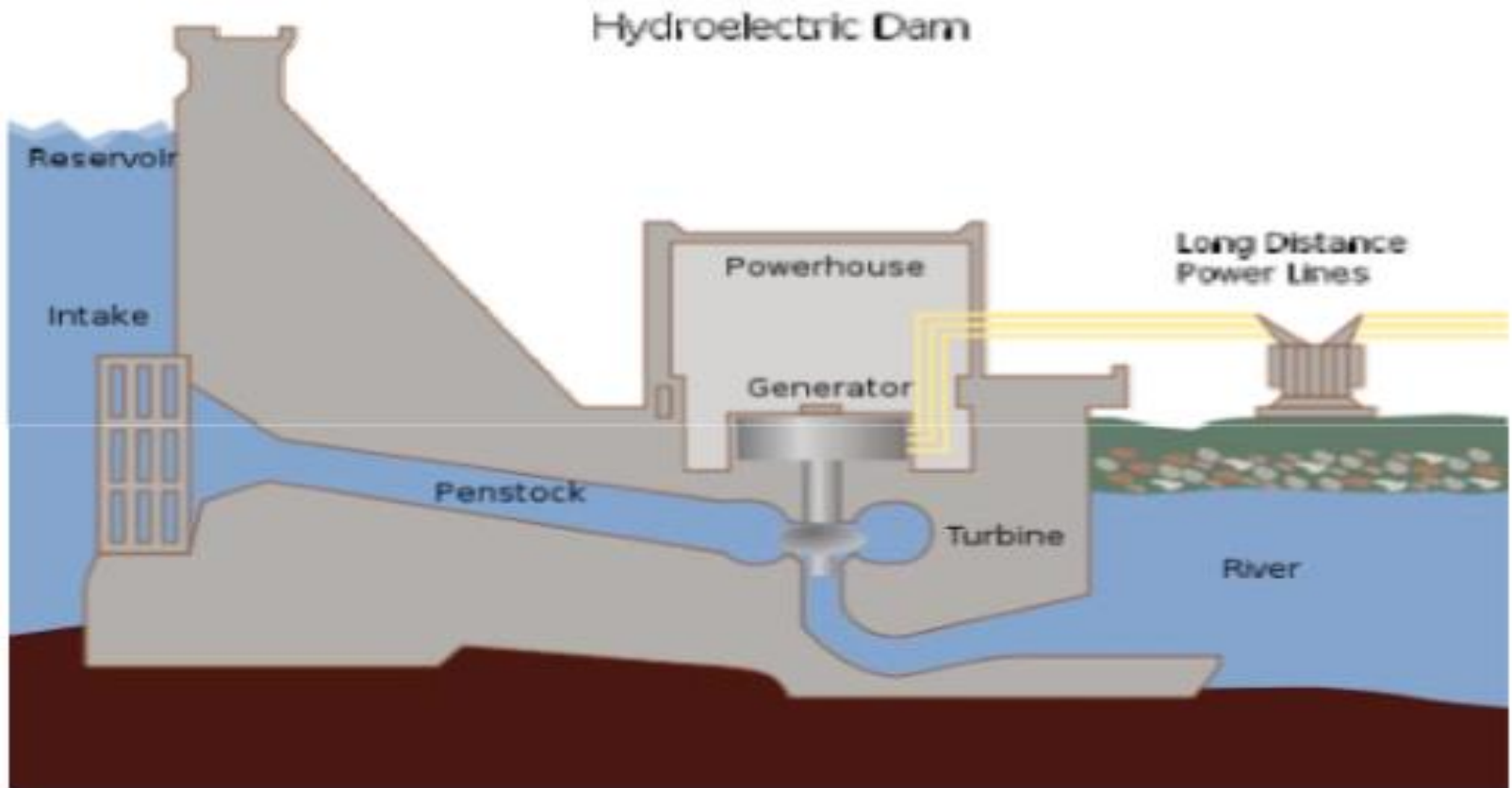

4.2 Classification of Hydropower Plant

- Hydropower plants can be classified into different types based on the various criteria, as follow.
 - a) classification based on storage(hydraulic) characteristics
 - i. Run-off river plant
 - ii. Storage plant
 - iii. Pumped storage plants
 - iv. Tidal plants

Cont....

i. Run-off river plant

- Is located on a perennial river in which adequate discharge is available through out the year.
- The plant uses the water as it comes in the river without storing it.
- These plant are those which utilise the minimum flow in a river.
- A weir (or a barrage) is usually constructed across the river to maintain the required water level and the head for the power plant located on its side or downstream.

Cont....

- The run-off river plants are generally low head plants usually have a small pondage on the upstream to store some water during off-peak hours, which is later utilised during peak hours.
- The power stations constructed on diversion canals (irrigation & power canals) called diversion canal plants, can also be placed in this category.

Cont....

ii. Storage plants

- In storage (or reservoir) plants, a dam is constructed to create a large reservoir to permit carry over storage from the rainy season to the dry season.
- These plants can be designed for a constant flow much greater than the minimum natural flow
- The power house may be located at the foot of the dam or it may be located much away from the dam (on the downstream side)
- In such a case a power house is located at the end of the tunnels which carry water from the reservoir.

Cont....

- When the power house is located near the dam, as is generally done in low head installations; it is known as **concentrated fall hydroelectric development**. But
- When the water is carried to the power house at a considerable distance from the dam through a canal, tunnel or penstock; it is known as a **divided fall development**.

Cont....

iii. Pumped storage plants

- A pumped storage plant generates power during peak hours, but during the off-peak hours, water is pumped back from the tail water pool to the head water pool for future use.

Iv. Tidal plant

- Tidal plants are designed to make use of high tides occurring in the sea for the generation of power.
- These plants are constructed on the sea shore, and therefore do not require any storage of water.

Cont....

b) classification based on load (use) to meet the demand for electrical power.

i. base-load plant

- A base load plant is designed to take care of the base load of the power system. It is capable of supplying continuous power to the system through out the year.
- Both run-off river plants and storage plant can work as base load plants. however, if a runoff-river plant with out poundage is designed as a base-load plant, the design discharge should be taken as corresponding to the minimum flow of the river.

Cont....

ii. Peak-load plants

- A peak-load plant is designed to take care of the peak load of the power system. It operates only during the period of the peak load.
- Pumped storage plants are usually designed as peak-load plant

Cont...

13

c) Classification based on head on turbines

- Low head plants (head < 15 m)
- Medium head plants (head between 15 – 50 m)
- High head plants (head between 50-250 m)
- Very high head plants (head > 250 m)

d) Classification based on Plant capacity:

- Micro hydropower plant (has a capacity < 5 MW)
- Medium capacity plant (has a capacity 5MW to 100MW)
- High capacity plants (has a capacity 100 to 1000MW)
- Super Hydropower plant (has a capacity >1000 MW)

4.3 Principal Components of Hydroelectric Scheme

- A hydroelectric development scheme ordinarily includes:
 - ✓ a storage or diversion structures,
 - ✓ intake structure,
 - ✓ conveyance system which carry the water from the reservoir to the power house. It may includes canals, pipes, penstocks or tunnels
 - ✓ Powerhouse which is a building for housing the equipment required for generation of power such as turbines generators.

Cont....

- In addition to these
- ✓ trash racks at the entrance to penstock, canal and penstock gates,
- ✓ A forebay,
- ✓ A surge tank and other accessories may be required and also
- ✓ A tailrace channel which is a channel from power house back to the river must be provided , if the power house situated at such a place that the draft tubes can not discharge water directly in to the river.

Cont....

- The major components of a hydroelectric scheme are discussed below.

1. Intake

- The intake structure is situated at the entrance of the canals, tunnels or pipes through which water is conveyed to the power house. They fulfill the following functions:
 - **Control** the flow of water using **a gate or valve**
 - Smooth easy and **turbulence free entry of water.** This is achieved by flaring the inlet mouth so as to provide bell mouth entry.

Cont....

17

- Stopping **coarse river borne** trash matter such as boulders, logs etc. from entering the conveyance passage.
- **Not** allowing **heavy sediment load** of the river in to the conveyance passage

Types of intakes

- The type of intake most suitable for a particular project will depend up on
 - ✓ The type of diversion or storage structure
 - ✓ The location of the power house

Cont....

- ✓ The conveyance system
- ✓ topography etc..
- The following 5 type of intakes are quite common.
 1. dam intake
 2. runoff –river intake
 3. cannel intake
 4. tower intake
 5. shaft intake

Cont....

2. TRASH RACK AND SKIMMERS

- Trash racks are provided to prevent the entry of debris into the conveyance system of hydropower scheme
- **Debris** carried in the incoming water can have **adverse impacts** on a **hydropower scheme** in that:
- It can **obstruct flow** along the conveyance structures, **interrupting power generation** or causing the water **to overflow and possibly** undermine the structures.

Cont....

- It can cause rapid deterioration of the penstock or turbine or cause a catastrophic failure, such as rupture of the penstock through a sudden blockage of flow through the nozzle (in the case of impulse turbines) or fracture of the runner blades (in the case of reaction turbines).

Cont....

3 Conveyance system

- Conveyance system is required to carry the water from the intake to the power. The conveyance system most suited for the project will also depend up on the number of factors, such as:
 - ✓ The topography
 - ✓ Discharge
 - ✓ Head and
 - ✓ Distance between the intake and the power house.

Cont....

- Various type of conveyance systems are discussed below.

I. Canals (Power Canal)

- which in most cases conveying water from intake structure to surge tank, forebay or pressure shaft, depending on the arrangement of the scheme.
- Canals are appropriate choice when the general topography of the terrain is moderate with gentle slopes.

Cont....

- However, when the ground is very steep and rugged, it becomes uneconomical to construct canals as it follows longer distances and/or needs provision of cross-drainage works and deep cuts and fills at a number of appropriate locations.
- In such cases, it is advisable to go for tunnels or pipes.

Cont....

II. TUNNELS

- Tunnels are underground conveyance structures constructed by special tunneling methods without disturbing the natural surface of the ground.
- In many modern high head plants, tunnels form an important engineering feature.
- In the headrace of water conveyance system, tunneling is popular because of the following reasons:
 - ✓ It provides a direct and short route for the water passage thus resulting in considerable saving in cost

Cont....

- ✓ Tunneling work can be started simultaneously at many points thus leading to quicker completion
- ✓ Natural **land scape is not disturbed**
- ✓ **Tunneling work has become easier** with development techniques of **drilling and blasting** and new mechanical equipment.

Cont....

- Tunnels of hydropower projects fall into two categories: **water carrying tunnels** and **service tunnels**.

Water carrying tunnels :

- These include **head race** or **power tunnels**, **tail race tunnels** or **diversion tunnels**.
- Flows in water tunnels are usually under pressure (pipe flow), but sometimes free-flow (open channel flow) can be experienced, especially, in tailrace tunnels.

Cont....

- **Head race tunnels:** are tunnels that convey water to the surge tank. These are pressure tunnels
- **Tail race tunnels:** could be free flowing or pressure tunnels depending on the relative position of turbine setting and tail water level.
- **Diversion tunnels:** are constructed for the purpose of diverting the stream flow during construction period.

Cont....

Service tunnels:

- These may be:
 - **Cable tunnels:** to carry cables from underground power house to the switch yard
 - **Ventilation tunnels:** fitted with fans at the open end to supply fresh air to the underground
 - **Access or approach tunnels:** this is a passage tunnel from surface to underground power house.

Cont....

CLASSIFICATION OF TUNNELS

- In addition to the above classification tunnels may be classified **on the basis of shape, alignment and design aspects.**
- **Shape:** Tunnels are either circular or non-circular in shape.
 - **Circular tunnels:** are most suitable structurally. They are more stable when the internal pressure is very high.
 - **Non-circular tunnels:** have a flat floor, nearly vertical or gently flaring walls and an arching roofs. The horse-shoe shape is the most popular and convenient from the point of view of construction.

Cont....

30

Commonly adopted shapes :

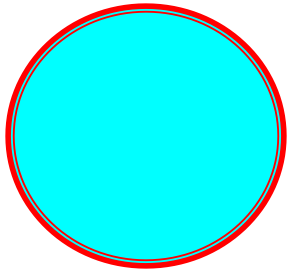

a) Circular shape

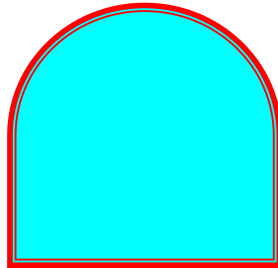

b) Horseshoe shape

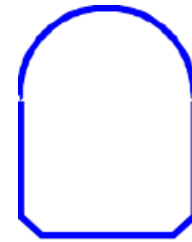

C) D-shape

Cont....

III. PENSTOCK

- A penstock is the conduit that is used to carry water from the supply sources to the turbine. This conveyance is usually from a canal or reservoir.
- Penstocks classified based operation conditions:
 - ✓ **Pressure penstock** : requires that the water discharging to the turbine always be under a positive pressure (greater than atmospheric pressure).

Cont....

- ✓ **Siphon penstock:** is constructed in such a way that at points in the penstock the pressure may be less than atmospheric pressure and sections of the conduit act as a siphon.
- This requires that a vacuum pump or some other means for initiating the siphon action must be used to fill the conduit with water and to evacuate the air in the conduit.

Cont....

33

PENSTOCK / 425 m (elev. difference)



Cont....

- Penstocks may be classified according to type of construction:
 - ✓ **Steel penstocks:** the most common type of installation, due to simplicity in fabrication, strength, and assurance that they will perform in a wide variety of circumstances.
 - ✓ **Cast-in-place or precast reinforced concrete pipe:** Very large diameters are somewhat impractical. Cast-in-place concrete pipes are usually limited to heads of less than 35 m.
 - ✓ **Fiberglass and polyvinyl chloride (PVC) plastic pipe:**
 - ✓ **Wood stave pipes**

Cont....

4. FOREBAY

- A **forebay**, also called a **head pond**, is a basin located at the end of a power canal just before the entrance to the **penstock or pressure shaft**.
- It acts as a **transition section between the power canal and the penstock**.
- It is formed simply by widening the power canal at the end.
- Through Forebay, the water carried by a power canal is distributed among penstocks that lead to turbines.

Cont....

- Water is temporarily stored in a Forebay in the event of rejection of load by turbine and is withdrawn from it when there is demand.
- Thus it is a sort of regulating reservoir. It is located at the end of the canal.
- The Forebay is used:
 - **To decrease the distance to the power house so as to get the turbine on and off within a shorter period.**
 - **To decrease the length of the penstock**
 - **To halt the propagation of pressure waves to the power canal**

Cont....

37

Components of a Forebay

➤ **The basin**

- ✓ Used to store water and sediment (if any)

➤ **The spillway**

- ✓ Used to dispose excess water that might enter the forebay

➤ **The bottom outlet**

- ✓ Used for flushing out of the sediment stored in the basin as well as for de-watering the forebay and the power canal for maintenance

Cont....

38

➤ The penstock inlet

- ✓ Serves in controlling flow into the pressure conduit and in preventing floating debris from entering the conduit.
- ✓ It also provides smooth transition between the basin and the conduit.

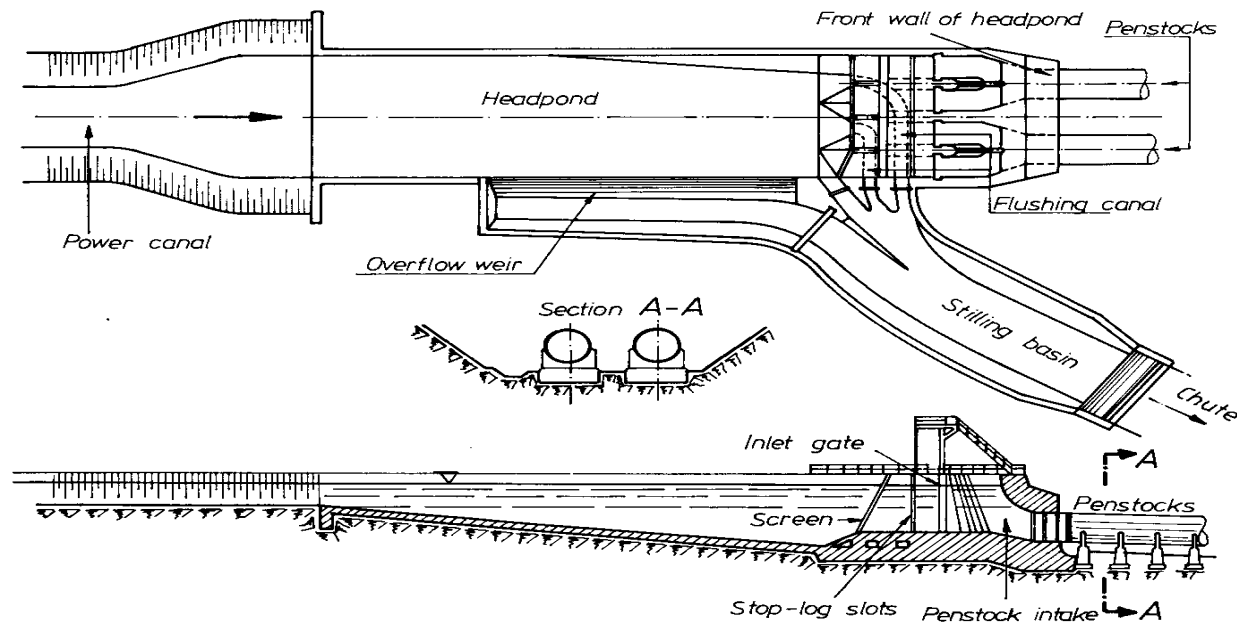

Cont....

5. SURGE TANKS

- Surge tanks are large cylindrical tanks provided near the downstream end of the long penstock to relieve excess pressure caused by sudden closure of the valve.
- They also provide a supply of water when the valve is suddenly opened.

Cont....

40

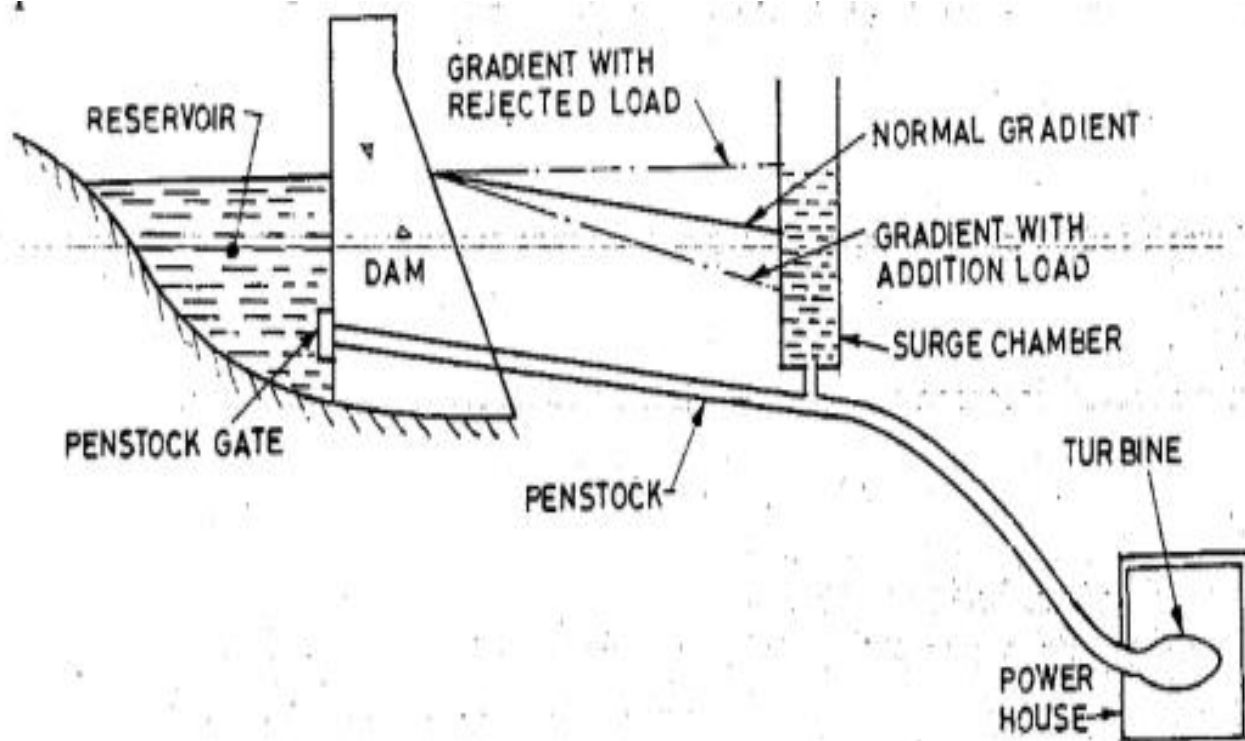

Cont....

6. POWER HOUSE

- The power house is a building constructed for housing and protection of various hydraulic and electrical equipment required for the generation of power , such as spiral casing, turbine, draft tube, generator, etc...

Cont....

7. DRAFT TUBES

- The draft tube is a conduit discharging water from the runner to the tail race.
- Draft tubes are provided:
 - To recover the velocity energy of the water leaving the runner as much as possible, which other would have gone to waste as an exit loss, thus increasing the dynamic draft head
 - To utilize the vertical distance between the turbine exit and the tail water level, called the static draft head.

Cont....

43

- Two types: elbow and vertical

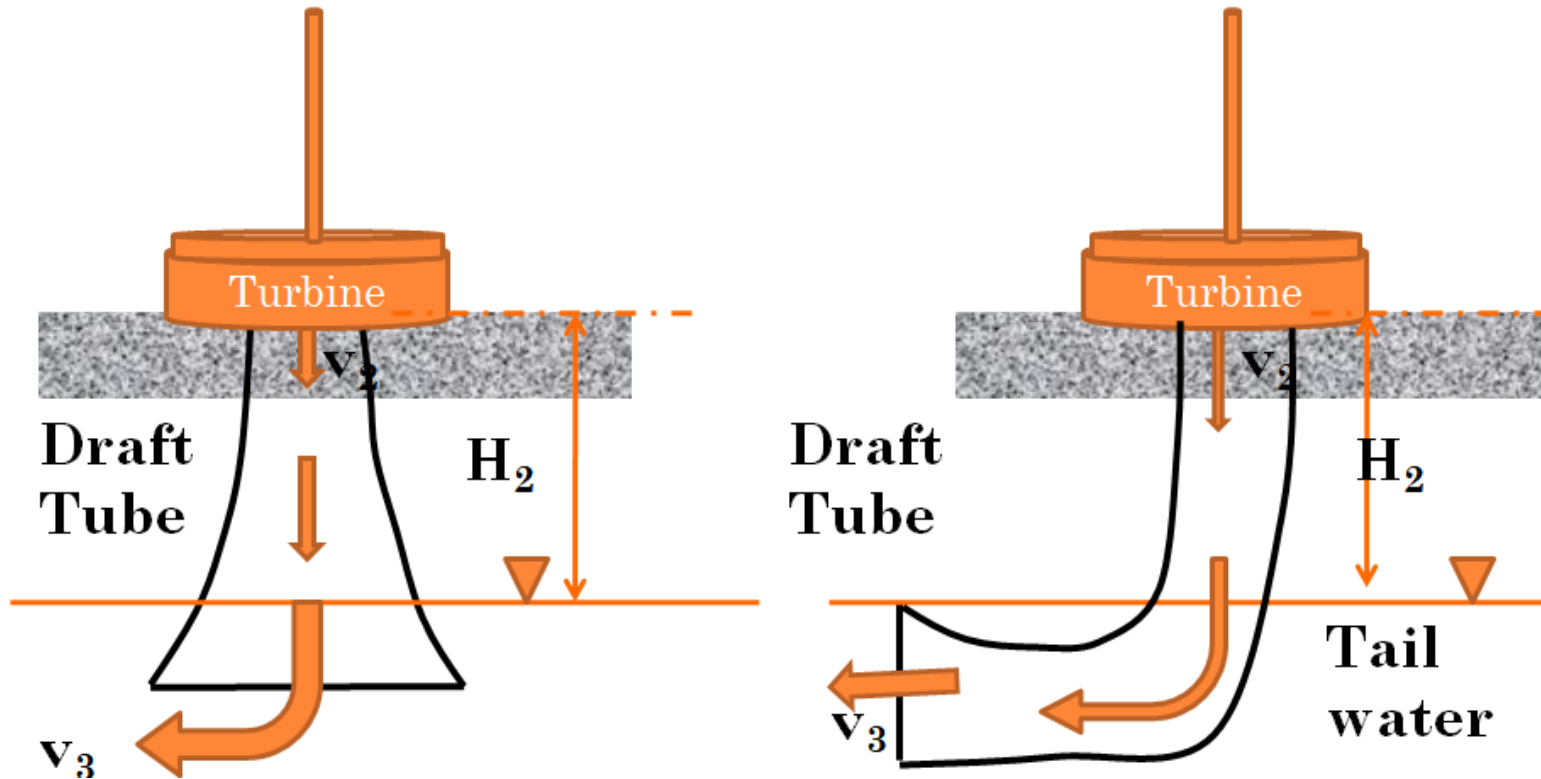

Cont....

8. TAIL RACE

- The tail race is the channel (or tunnel) in which the water after passing through the turbine is discharged.

4.4 Hydraulic Turbines

- The turbine is made to convert hydraulic energy (potential and kinetic) into rotational mechanical energy on the turbine shaft.
- The flow discharge is controlled by an aperture mechanism just in front of the turbine runner.
- The rotating part of the turbine or water wheel is often referred to as the runner.
- The shaft is directly connected to an electric generator that further converts the mechanical energy into electric energy.

Cont....

- A hydro turbine is usually tailor made in order to fit a particular net hydraulic head and a design flow discharge.
- However, there are two different categories of turbines, - they are based on two different principles of energy conversion:
 - **Impulse turbines or velocity turbine and**
 - **Reaction turbines or pressure turbine**

Cont....

Impulse Turbines

- Where all the hydraulic energy entering the turbine is converted into velocity energy in the stationary parts in front of the runner.
- The runner of the impulse turbine is only partly filled with water, and the runner operates in nearly atmospheric pressure.
- The **Pelton Turbine** is the most commonly used type in this category, and it is used for the highest heads.

Cont....

48

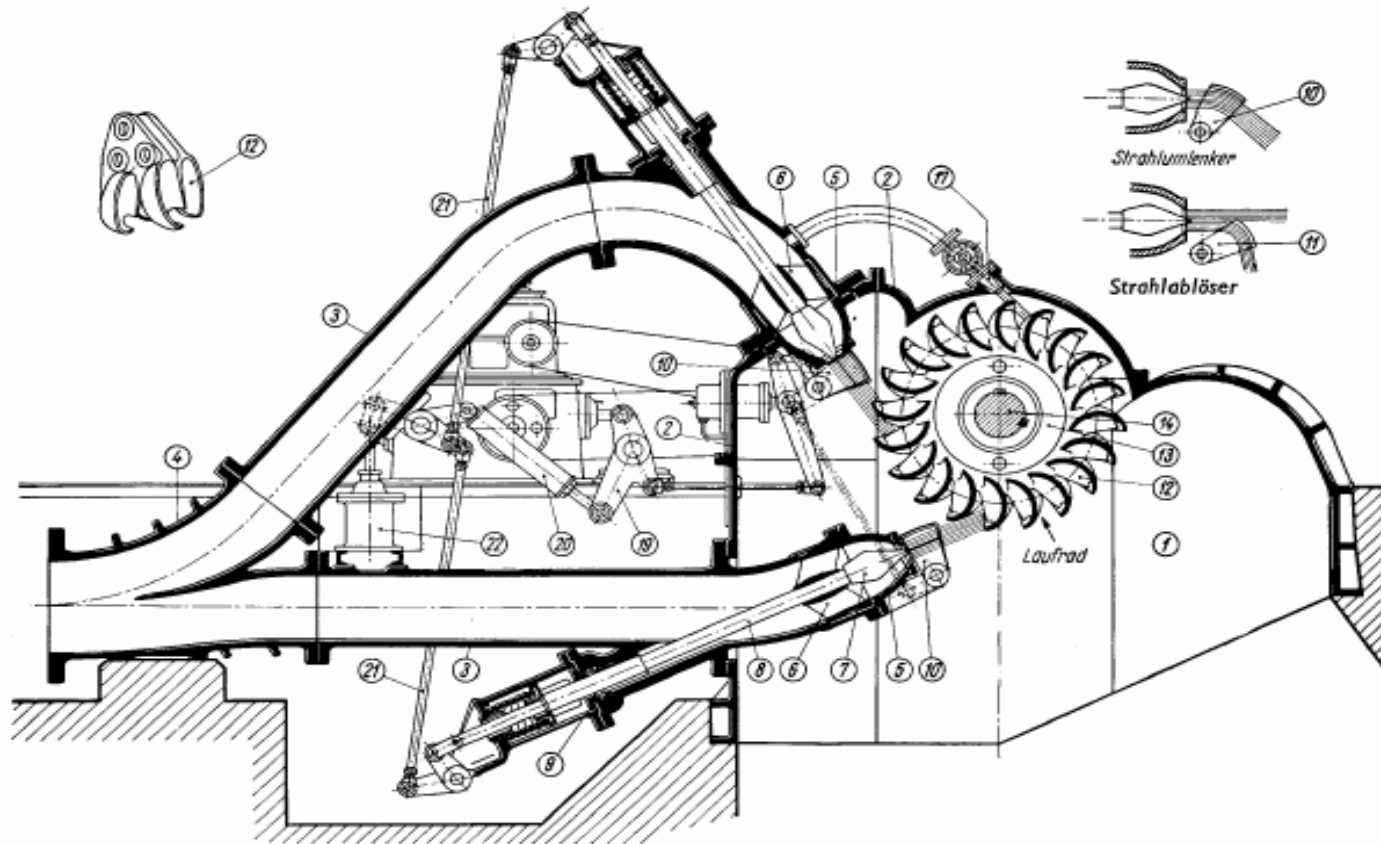

Pelton turbine

Cont....

Reaction turbines

- In reaction turbines only a part of the inlet hydraulic energy is converted into velocity energy in the stationary turbine parts.
- Thus, the conversion of hydraulic to mechanical energy in the runner can be divided into two:
 - The impulse action caused by the change of velocity direction from the runner inlet to the outlet, and
 - The reaction contribution caused by the pressure drop through the runner.

Cont....

- The pressure drop is obtained because the runner is completely filled with water.
- In the draft tube diffuser (Connecting the outlet of the turbine runner to the tail race) some of the velocity energy at the runner outlet is converted to potential energy.
- Francis, Kaplan and Bulb turbines belong to this group

Cont....

51

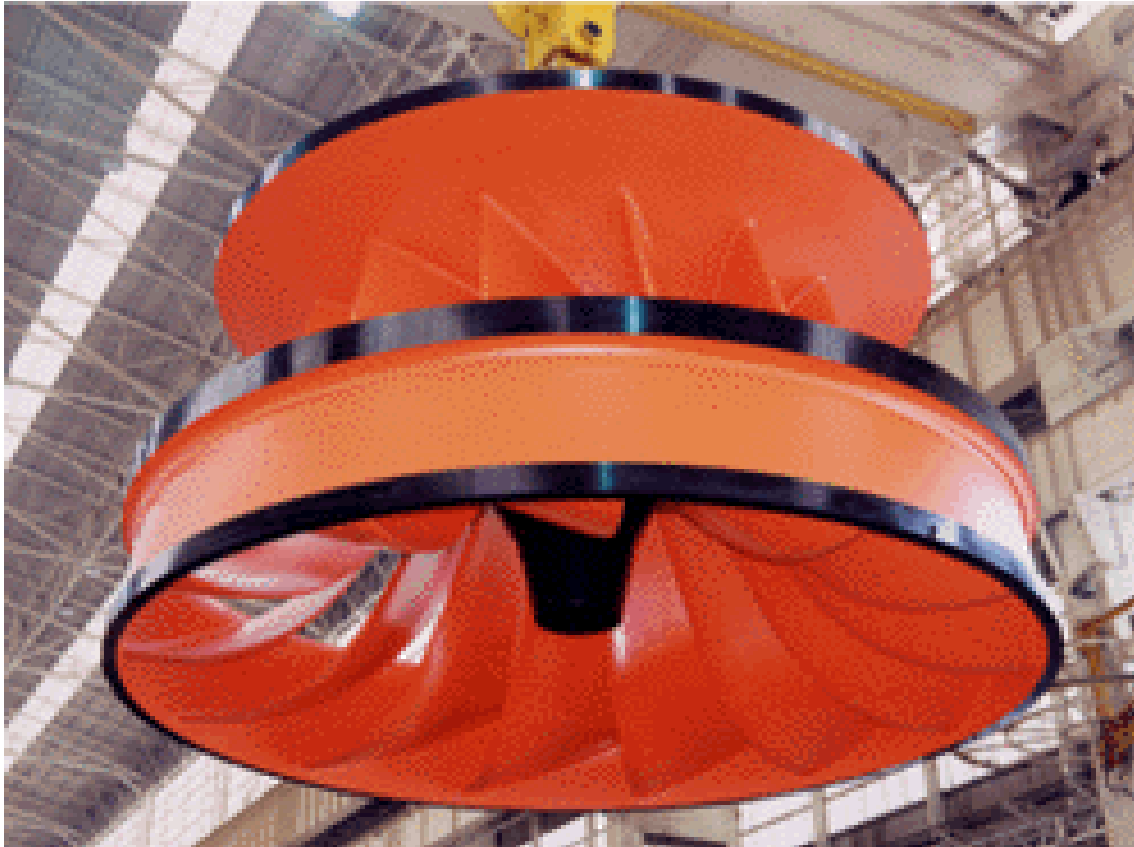

- Water flows through the runner to spin the turbine

Francis Turbine

Cont....

Francis turbines

- It is a reaction turbine developed by an English born American Engineer, Sir J.B. Francis.
- The water enters the turbine through the outer periphery of the runner in the radial direction and leaves the runner in the axial direction, and hence it is called 'mixed flow turbine'.
- It is a reaction turbine and therefore only a part of the available head is converted into the velocity head before water enters the runner.
- The pressure head goes on decreasing as the water flows over the runner blades.

Cont....

- The static pressure at the runner exit may be less than the atmospheric pressure and as such, water fills all the passages of the runner blades.
- The change in pressure while water is gliding over the blades is called 'reaction pressure' and is partly responsible for the rotation of the runner.
- A Francis turbine is suitable for medium heads (45 to 400 m) and requires a relatively large quantity of water.

Cont...

54

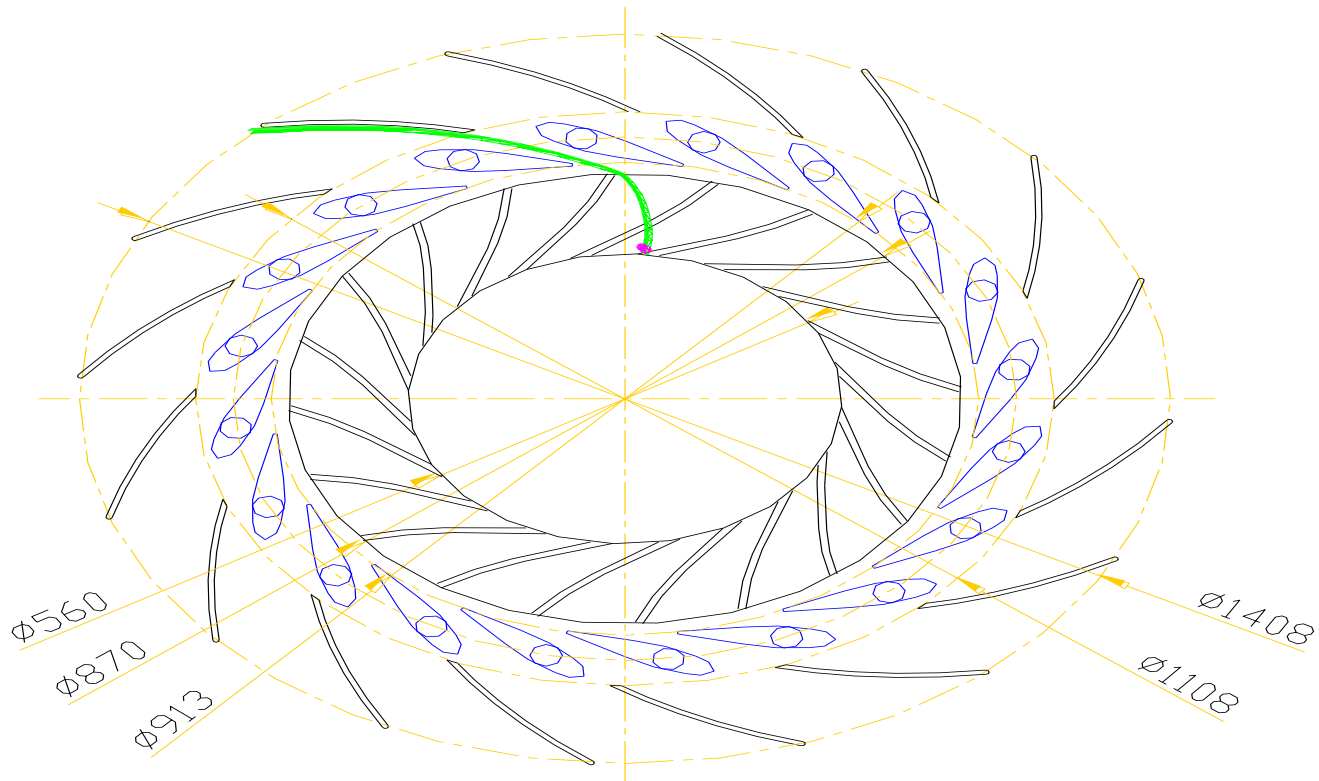

**R a d i a l v i e w
runner guide vanes and stay vanes**

Cont....

55

- Kaplan turbine runner



Kaplan Turbine



Cont....

56

Major Parts of A Kaplan Turbine

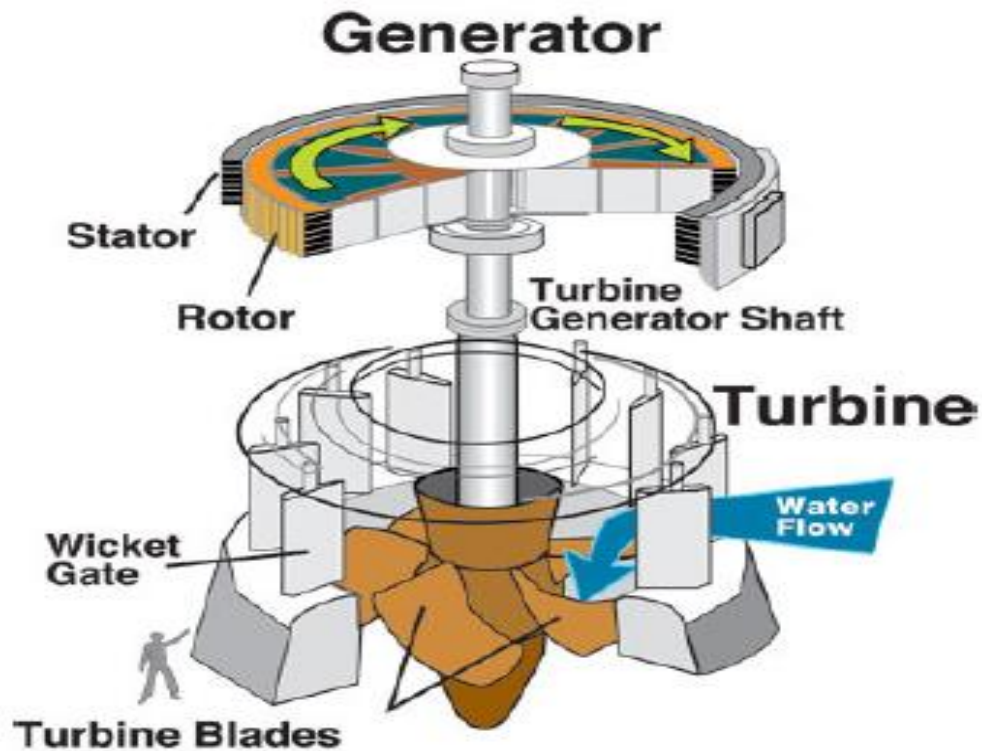

Cont....

57

Bulb Turbine

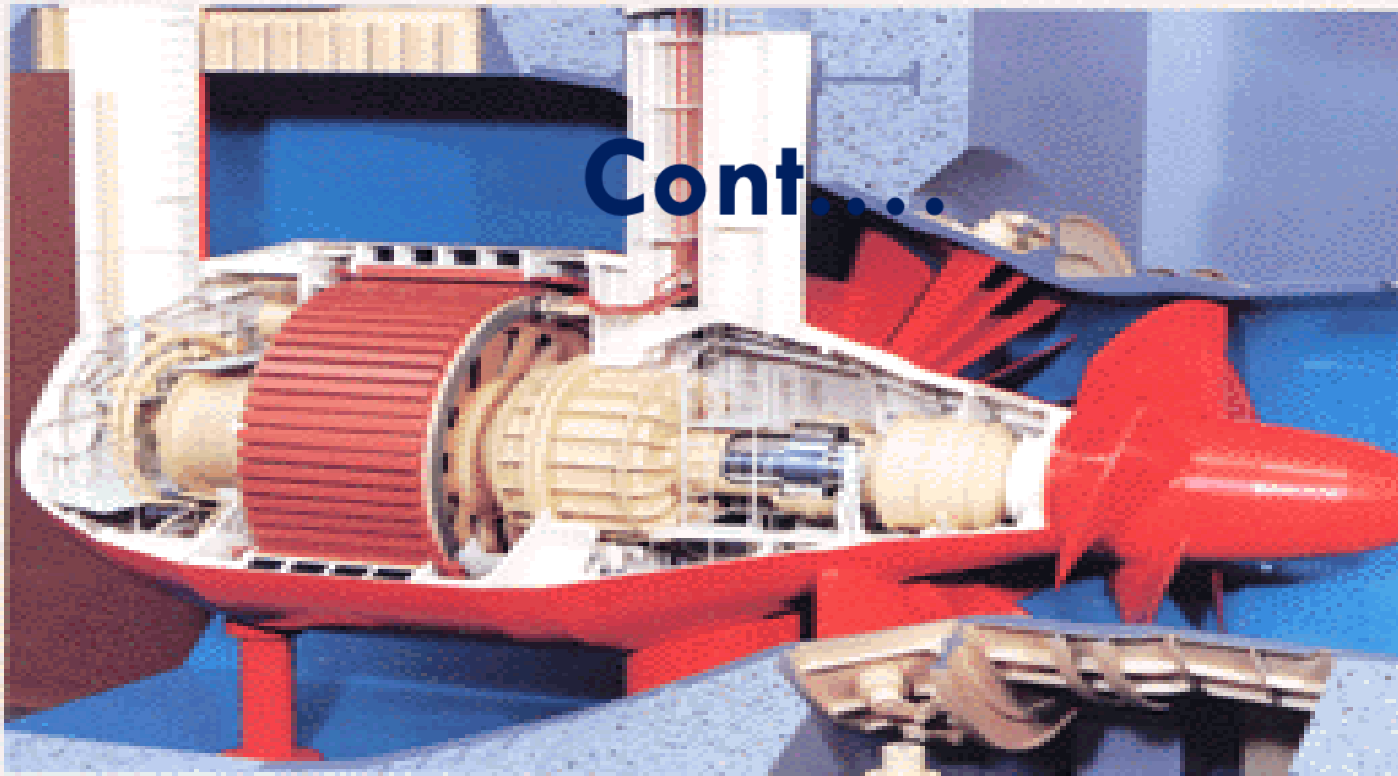

THANK YOU