

# CHAPTER 2

## Introduction to Control Systems

### ❖ Contents

- Introduction
- Examples of Control Systems
- Elements of a basic structure of control system
- Types of Control System

## 2.1. Introduction

**Control systems** played an important role in the advancement and improvement of engineering skill. Practically every activity in our day to day life is influenced by some sort of control system. It plays an important role in the working space vehicles, satellites, guided missiles etc.

Generally control systems are found in number of practical application like computerized control system systems, transportation systems, power systems, temperature limiting systems, robotics etc.

cont. ...

## What is Control System?

To define *control system* let us define first *system* and *control* separately.

➤ **What is system?**

➤ **What is control?**

❖ **System:** it is a combination of or arrangement of different physical components which act together as an entire unit to achieve a certain objective. Every physical object is actually a system (system can be physical, Ecological and biological).

Example

✓ **classroom:** it is a good example of physical system. It is a combination of benches, blackboard, fans, and lighting arrangement.

## Cont. ...

- ❖ **Control:** The meaning of control is to direct, regulate or command.
- ❖ **Control system:** It is a system to provide a desired function, involving some control action in it.
  - It is a system **Controlling the operation of another system.**
  - It is a system that can **regulate itself and another system.**
  - It is a **device or set of devices** to manage, command, direct or regulate the behaviour of other device(s) or system(s).

### Examples:

- ***Lecturer teaching in class room:*** as he/she tries to direct, regulate or command the students to achieve the objective which to impart (give a share) a good knowledge to the students.

## Cont. ...

- *Switching lamp ON and OFF using switch:*

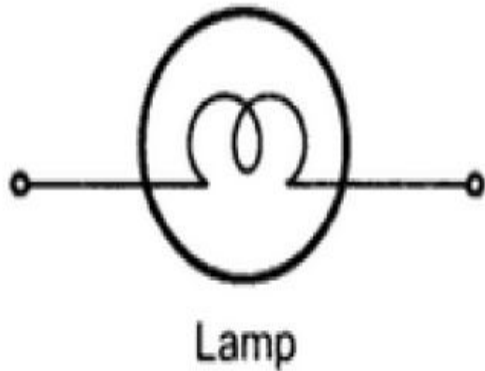

(Physical system)

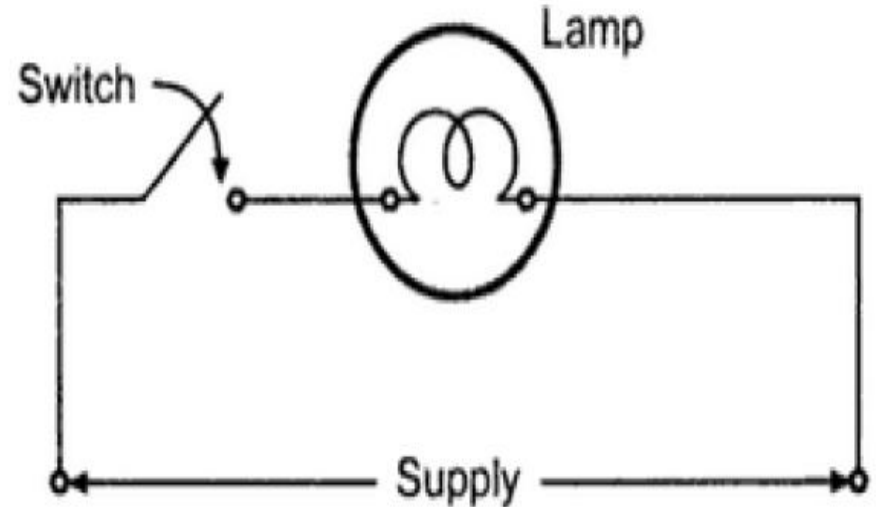

(Control system)

## Cont. ...

### ❖ Automatic control

- It is one of **most significant area** of science and technology.
- It is control operations in which no human intervention is required.
- It is a **combination of components** that act together in such a way that the overall system behaves automatically in a prespecified desired manner.
- It requires both **rather strong mathematical foundation** and **implementation skills** to work with controllers in practice.
- It have a **central aim** of developing control strategies to **improve performance of a system**.

## Cont. ...

### ❖ **Distinct characteristics of Automatic control**

- Reduces human participation in all technical activities.
- Decreases labour cost.
- Allows the production of more goods.
- Allows the construction of more works.
- Reduces work hazards.

## Cont. ...

### ❖ Some application areas of automatic control

- various machines and apparatus {Refrigerator, Water heater, washing machine, TV remote control, .....}
- Industries {Food, paper, cement, car, sugar, steel, plastics, clothes, Electrical power plants, .....}
- transportation systems {cars, airplanes, ships, submarines,...}
- robots, computers
- farming {green houses, irrigation, .....}
- medicine and etc. ...

## 2.2. Examples of Control Systems

### 1. Water level control

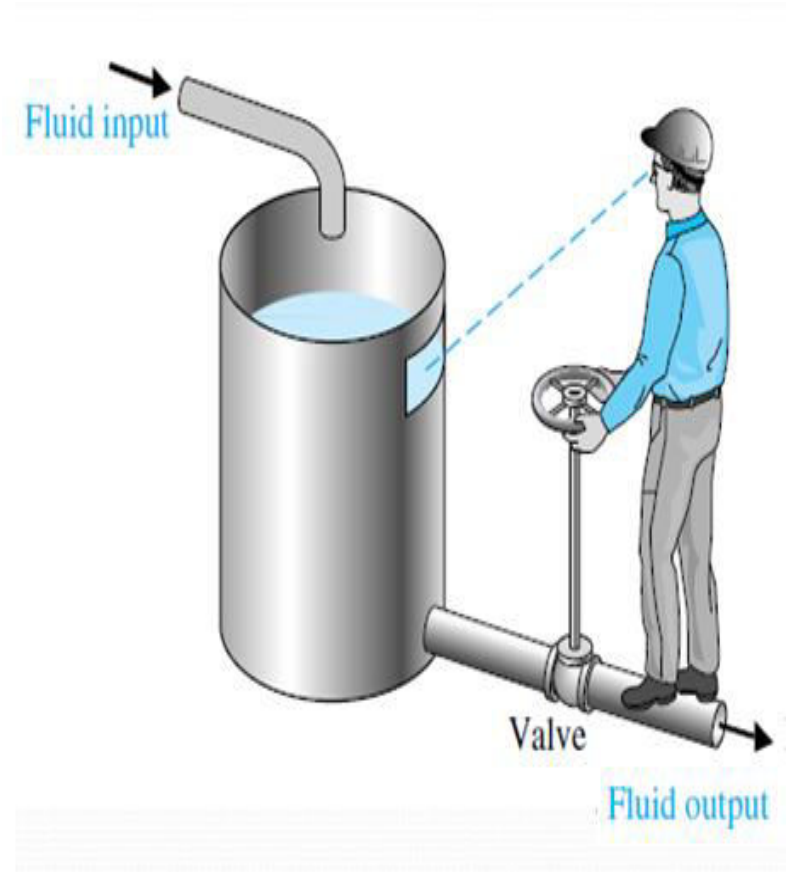
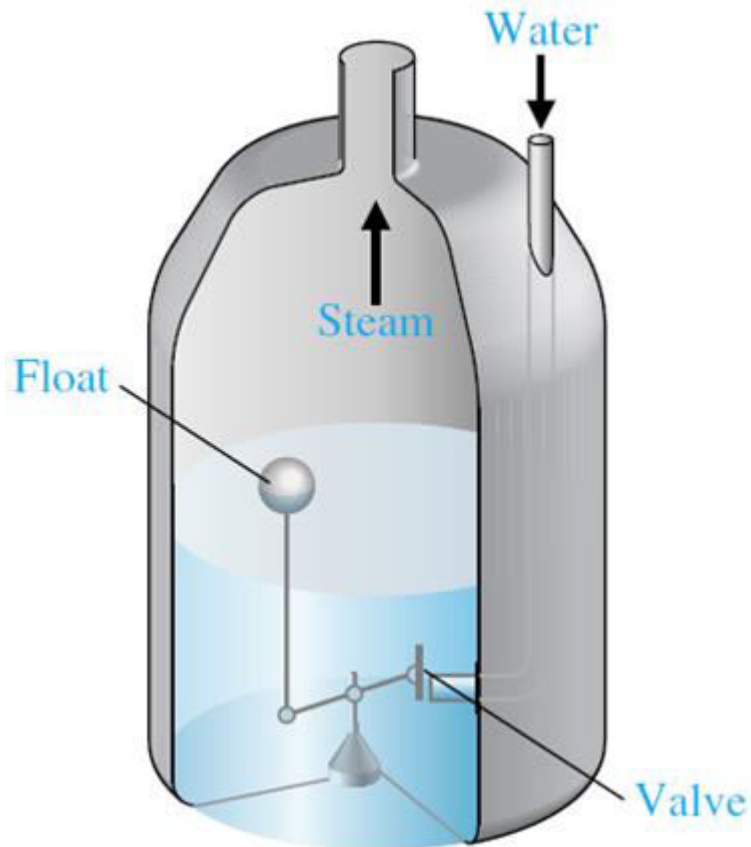

# Cont. ...

## 2. Fluid flow control

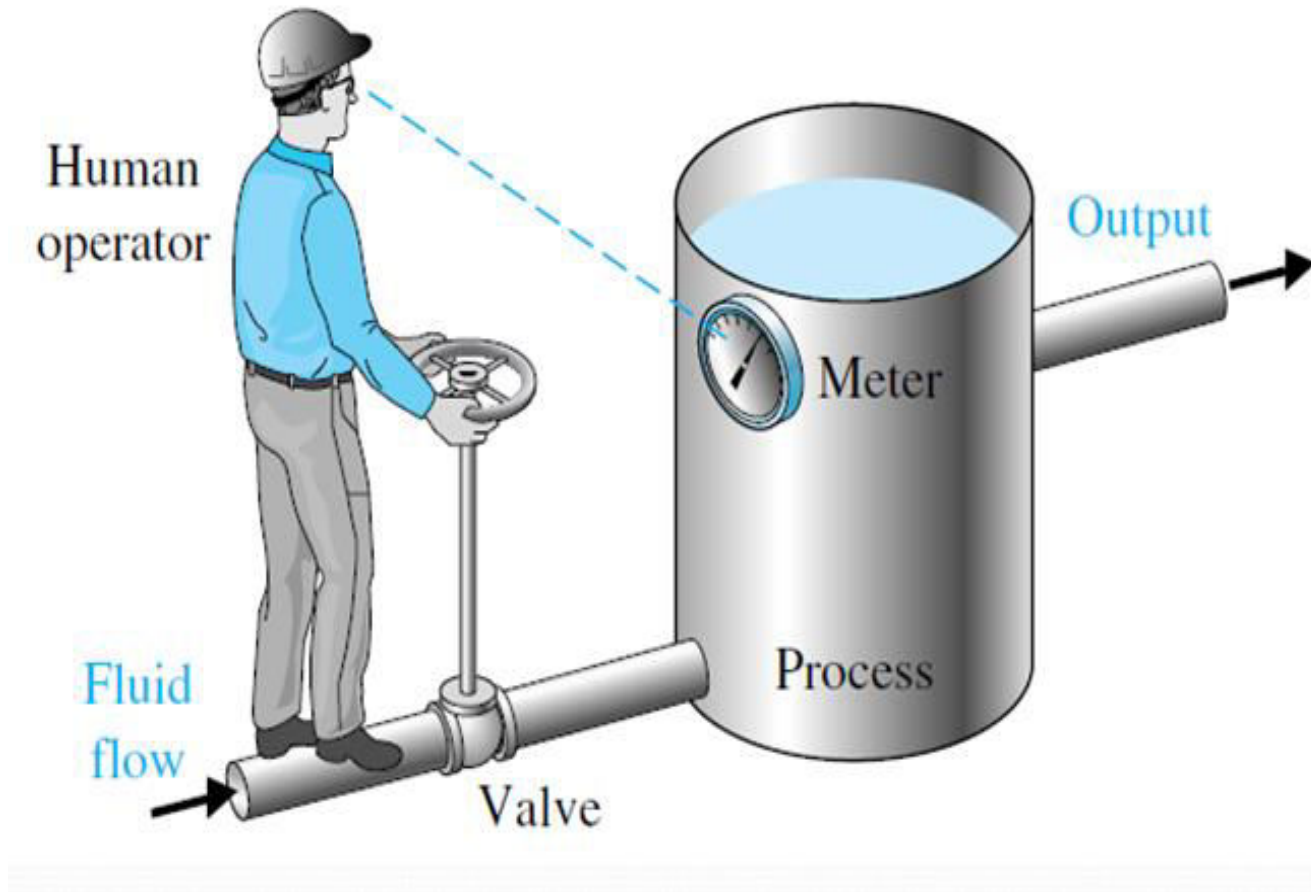

# Cont. ...

## Fluid flow control

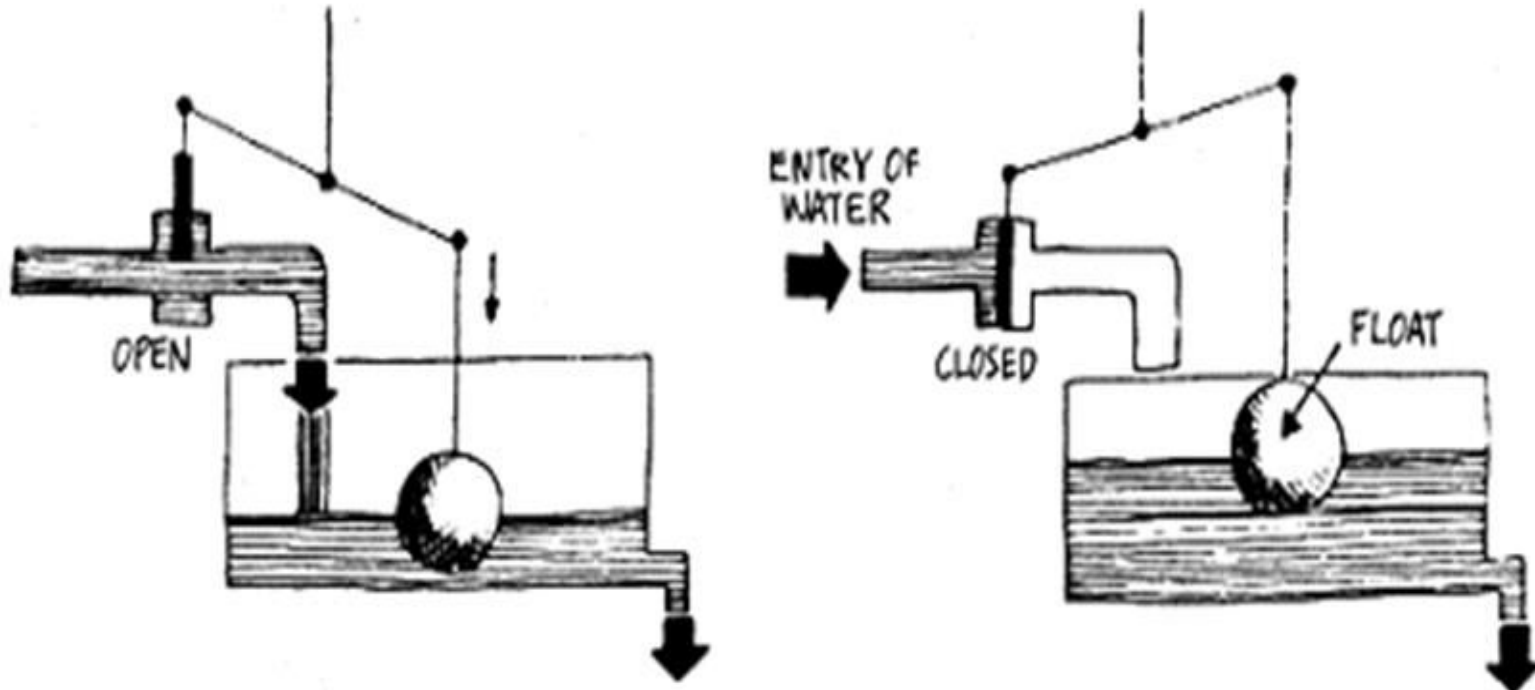

# Cont. ...

## 3. Temperature control of an Electric furnace

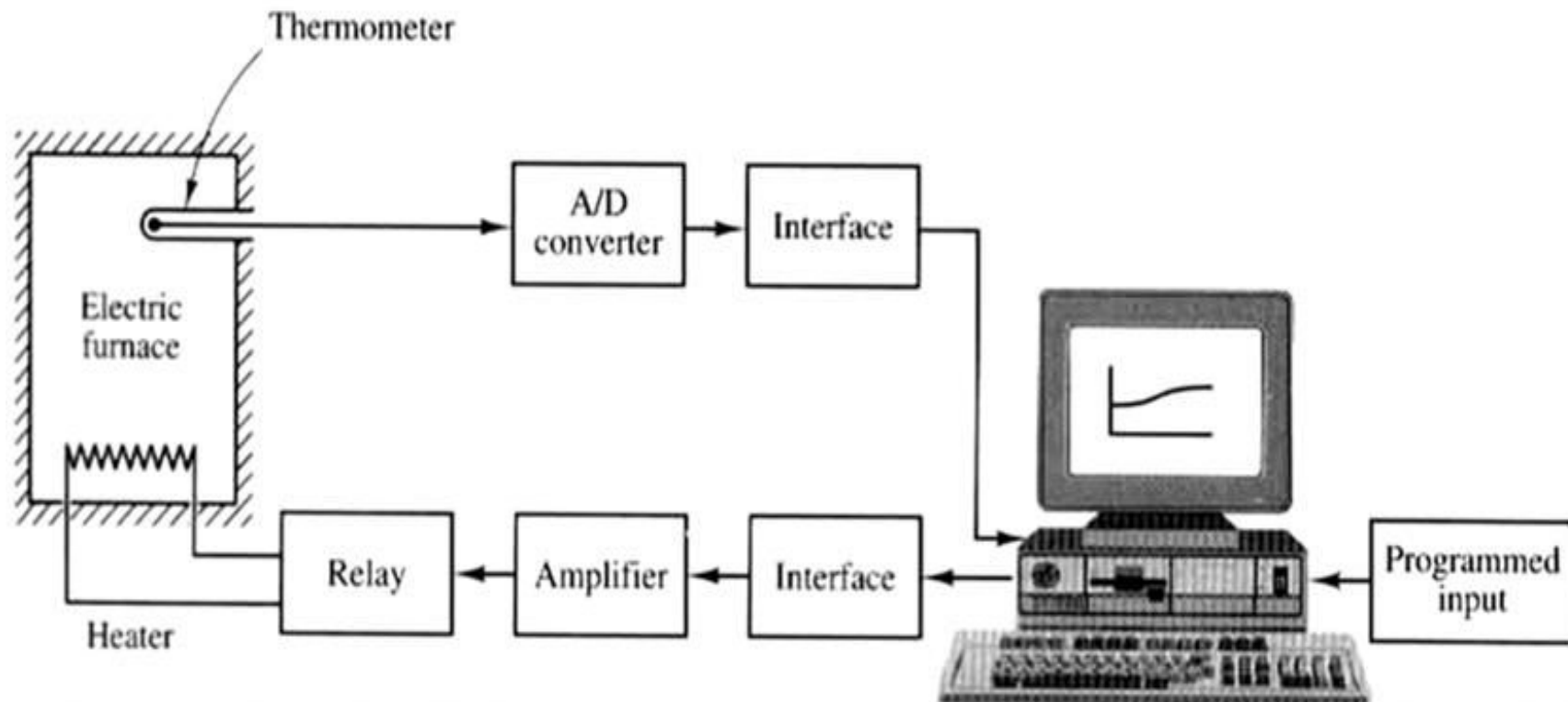

## 2.3. Elements of a basic structure of control system

### 1. Controlled Variable:

- quantity or condition that is measured and Controlled.
- output of the system.

### 2. Manipulated Variable:

- quantity of the condition that is varied by the controller so as to affect the value of *controlled variable*.
- The factor that is changed to keep the measured variable at setpoint.

### 3. Control:

- measuring the value of *controlled variable* of the system and applying the *manipulated variable* to the system to correct or limit the deviation of the measured value from a desired value.

## Cont. ...

### 4. Plants:

- Piece of equipment / set of machine parts to perform a particular operation.
- Any physical object to be controlled.

E.g. a mechanical device, a heating furnace, a chemical reactor.

### 5. Processes:

- Natural or an artificial, progressively continuing operation that consists of a series of actions directed toward a particular result.
- Any operation to be controlled.

E.g. Chemical, biological processes

# Cont. ...

## 6. System:

- An entity with recognizable inputs and outputs.
- Interconnection of elements and devices for a desired purpose.
- For a system to perform a certain task, it must be excited by a proper input.

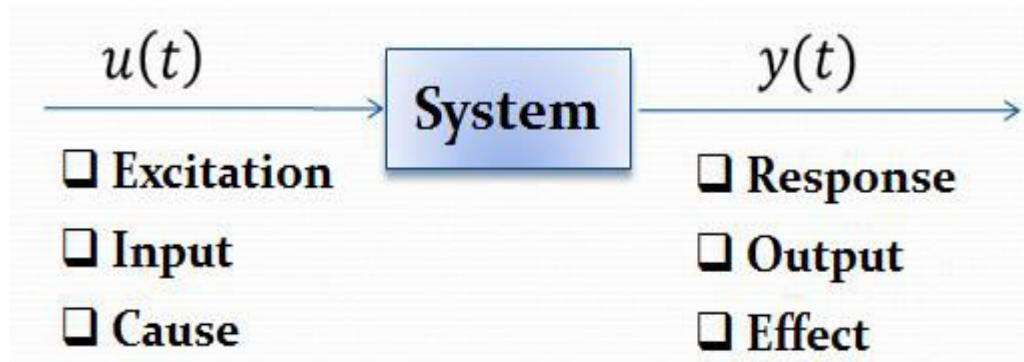

- System, input and output are related the following equation.

$$\mathbf{y(t) = Tu(t)}$$

where, T is an operator

## Cont. ...

### ❖ Basic Engineering problems

#### i. Analysis the problem:

- We are given  $u(t)$  and  $T$  and we are asked to determine  $y(t)$ .

#### ii. Synthesis problem:

- We are given  $u(t)$  and  $y(t)$  and we are asked to design  $T$ .

#### iii. Measurement problem:

- We are given  $y(t)$  and  $T$  and we are asked to measure  $u(t)$ .

✚ **“Control design problem doesn’t belong to any of these three problems”.**

## Cont. ...

❖ Given the system  $T$  under control and its desired response  $y(t)$ , find an appropriate input signal  $u(t)$ , such that, when this signal is applied to system  $T$ , the output of the system to be the desired response  $y(t)$ .

**$u(t)$  is called control signal.**

❖ **Control design problem:**

- Signal synthesis problem / synthesis of  $u(t)$ .
- Reduced to designing of a controller.

## Cont. ...

### 7. Disturbances:

- a signal that tends to adversely affect the value of the system.
- an unwanted input of the system.
- types of disturbance:
  - ✓ *Internal disturbance*: generated within the system.
  - ✓ *External disturbance*: generated outside the system.

### 8. Feedback Control system:

- A system that maintains a prescribed relationship between the output and some reference input by comparing them and using the difference (i.e. error) as a means of control.

## 2.4. Types of Control System

❖ **Natural Control Systems:** The systems inside a human being or biological system.

- Universe
- Human Body

### **Example:**

- Secretion of glands, sweat regulates temperature of human body.
- Blood sugar content is controlled by pancreas.
- Heartbeat of health human being for adult 18 and above normal resting heart rate is b/n 60 and 100 beats per minute (bpm).

## Cont. ...

❖ **Man-made Control Systems:** various systems designed and manufactured by human being.

### Example:

- Vehicles
- Aeroplanes
- Speed control of DC-motor
- Fluid level control
- Temperature control of a boiler
- Hydropower generator shaft speed control
- Robot control

❖ **Manual Control Systems:** The control operations that involve human action to make an adjustment.

### Example:

- Room Temperature regulation Via Electric Fan.
- Water Level Control (if controlled by human human being).

## Cont. ...

❖ **Automatic Control Systems:** It is control operations in which no human intervention is required.

### **Example:**

- Room temperature regulation via A.C.
- Human body temperature Control.

❖ **Basic classification of control system:**

- open loop systems
- closed loop systems

## Cont. ...

### ❖ Open-loop Control Systems:

- A system in which output is dependent on input but input is totally independent of output.
- Utilize a controller to obtain the desired response.
- Output has no effect on the control action. Output is neither measured nor feedback.
- No feedback – no correction of disturbances.

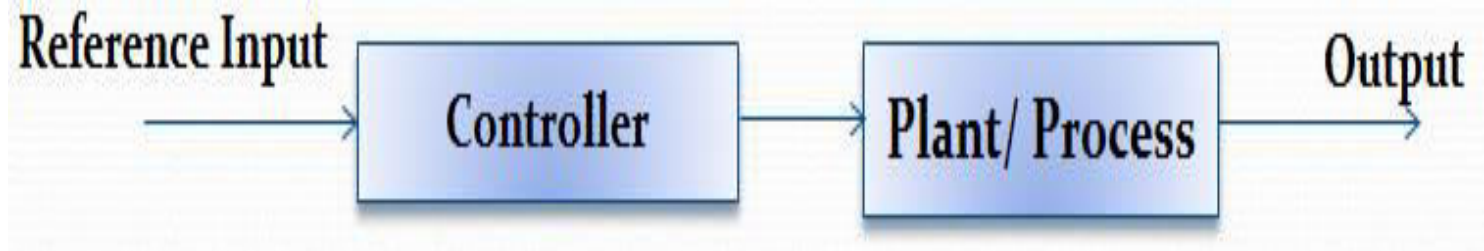

## Cont. ...

### Example:

- Washing machine
- Electric fan
- Electric stove

- Switch (ON-OFF)
- Sprinkler used to water lawn
- Traffic light controller

- ❖ Since in open loop control systems reference input is not compared with measured output, for each reference input there is fixed operating condition.
- ❖ Accuracy of the system dependent on the accuracy of calibration.
- ❖ Performance of the system is severely affected by the presence of disturbances, or variation in operating/ environmental conditions.

## Cont. ...

### ❖ Closed-loop Control Systems:

- The system in which controlling actions are somehow dependent on the output or changes in output. It is control system with feedback.
- Utilizes an additional measure of the actual output to compare the actual output with the desired output response. The measure of the output is called the **feedback signal**.
- Uses a measurement of the output and feedback of this signal to compare it with the desired output (reference or command).

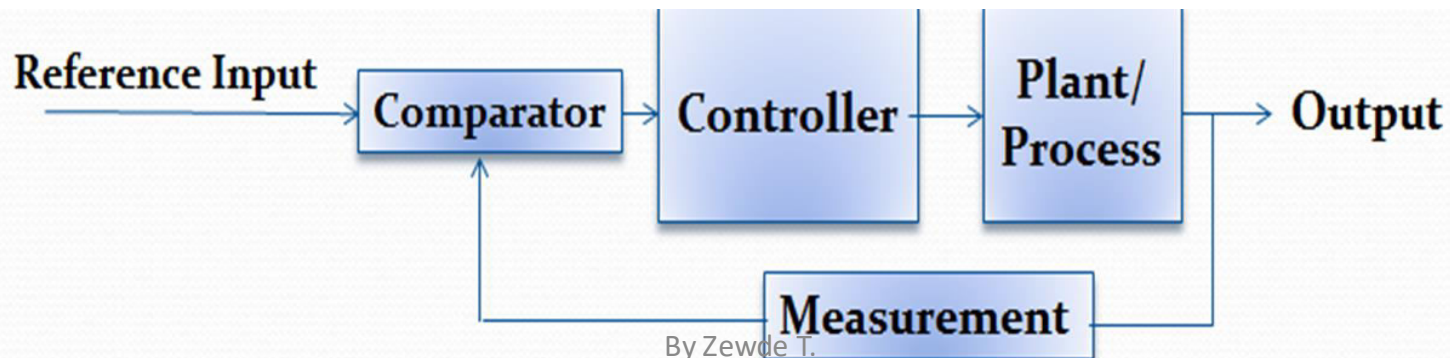

## Cont. ...

### ❖ Layout of closed-loop/feedback/control system

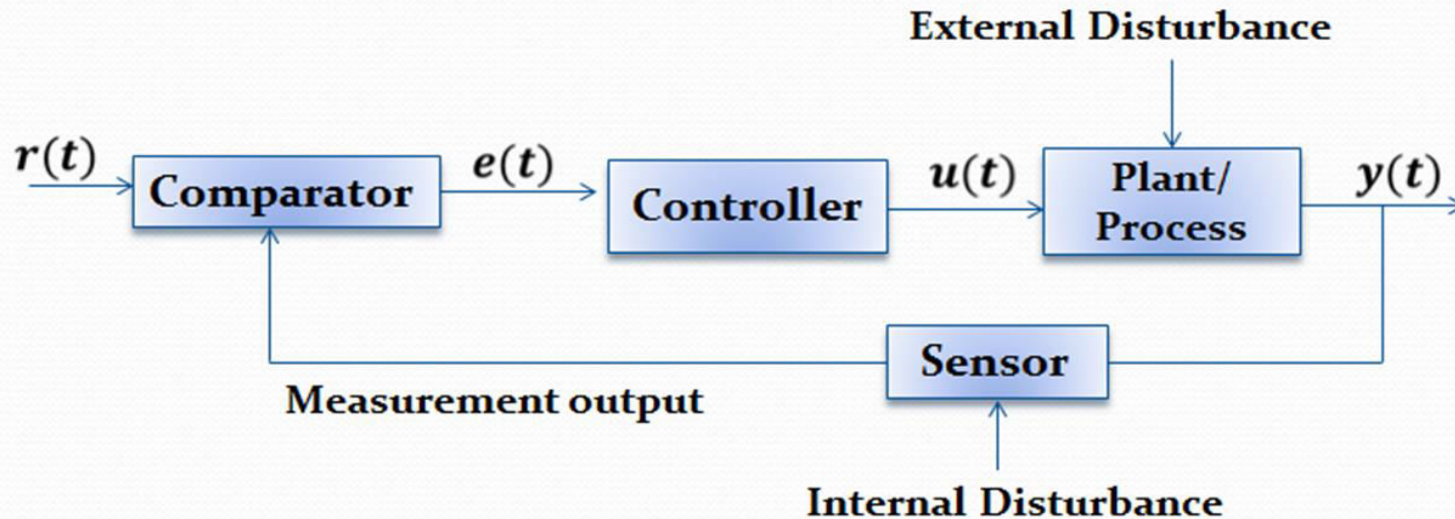

Where

- $r(t)$  : Reference Input / Desired output / Set point / Command signal
- $e(t)$  : Error signal
- $u(t)$  : Manipulated Variable / Control signal
- $y(t)$  : Actual Output / Controlled Variable

### Example:

- Refrigerator, water heater, liquid level control

## Cont. ...

- ❖ **Human being:** if a person wants to reach for a book on the shelf, the closed loop system represented as shown below:

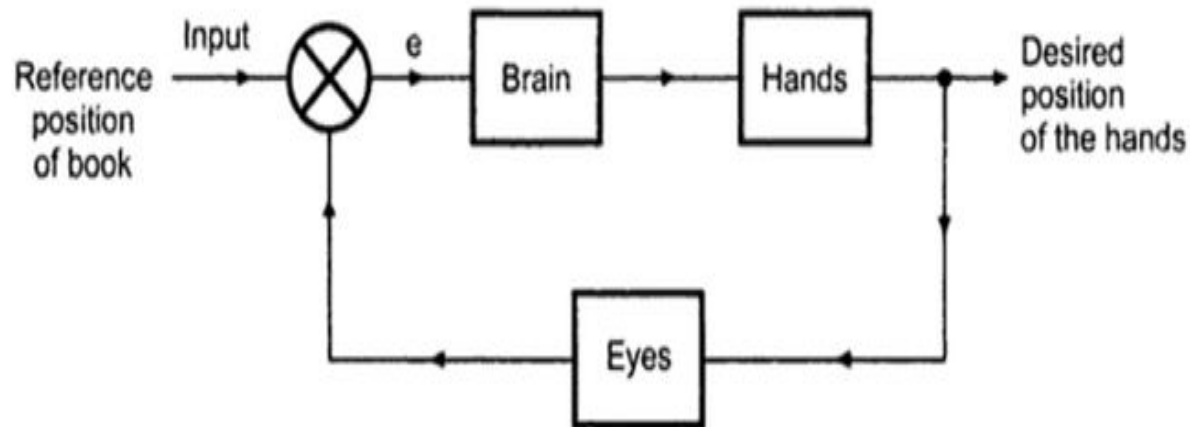

- Position of the book is given as the reference. Feedback signal is from eyes, compares the actual position of hands with reference position. Error signal is given to brain. Brain manipulates this error and gives signal to hand. This process continuous till to reach the position of book.

## Cont. ...

### ❖ Temperature control system:

- The aim is to maintain hot water temperature constant. Pressure thermometer 'p' used as feedback which send signal for comparison with set point and error actuates the valve which controls the flow rate of steam and eventually controlling temperature of water.

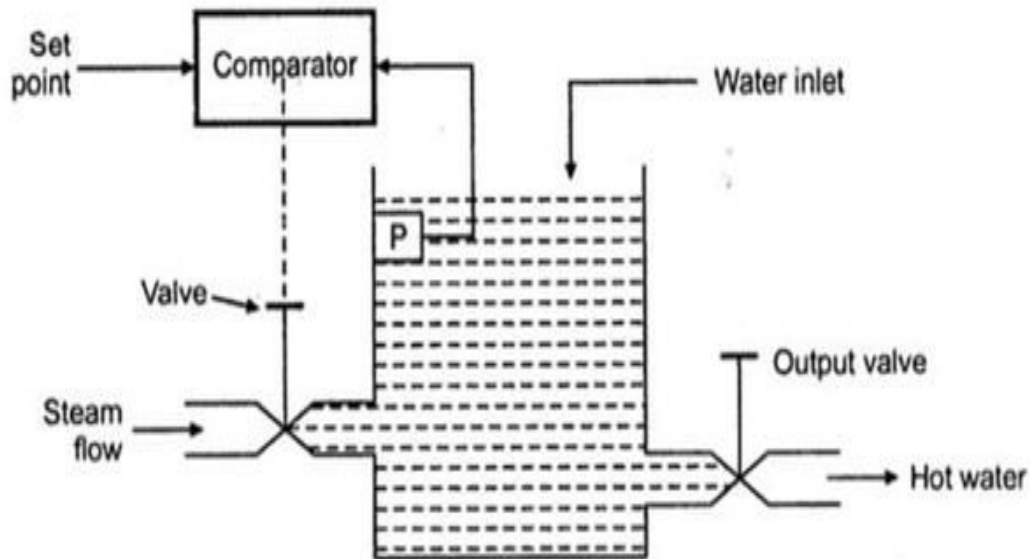

## Cont. ...

- Its block diagram representation

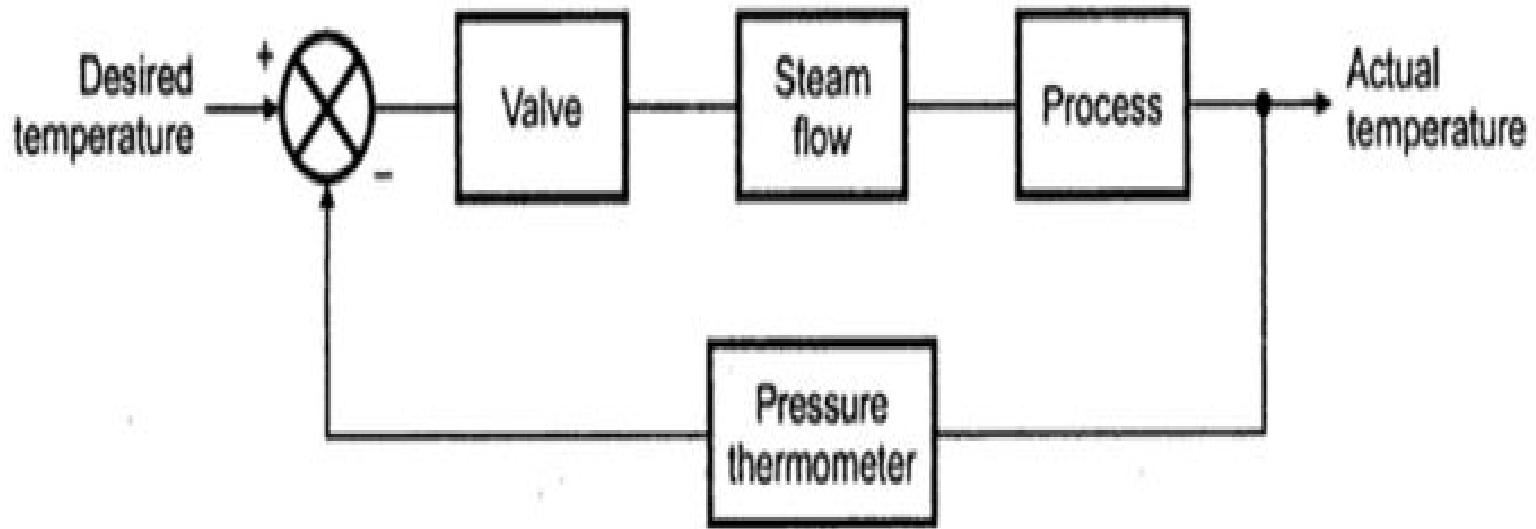

Block diagram of temperature control system.

## Cont. ...

### ❖ **Missile launching system:**

- The enemy plane is sighted by radar which continuously tracks the path of the aeroplane. Launcher computer calculates the firing angles in terms of launch command, which when amplified drives launcher. Launcher angular position feedback to the launcher computer and then missile is triggered when the error between command signal and missile firing angle becomes zero.

# Cont. ...

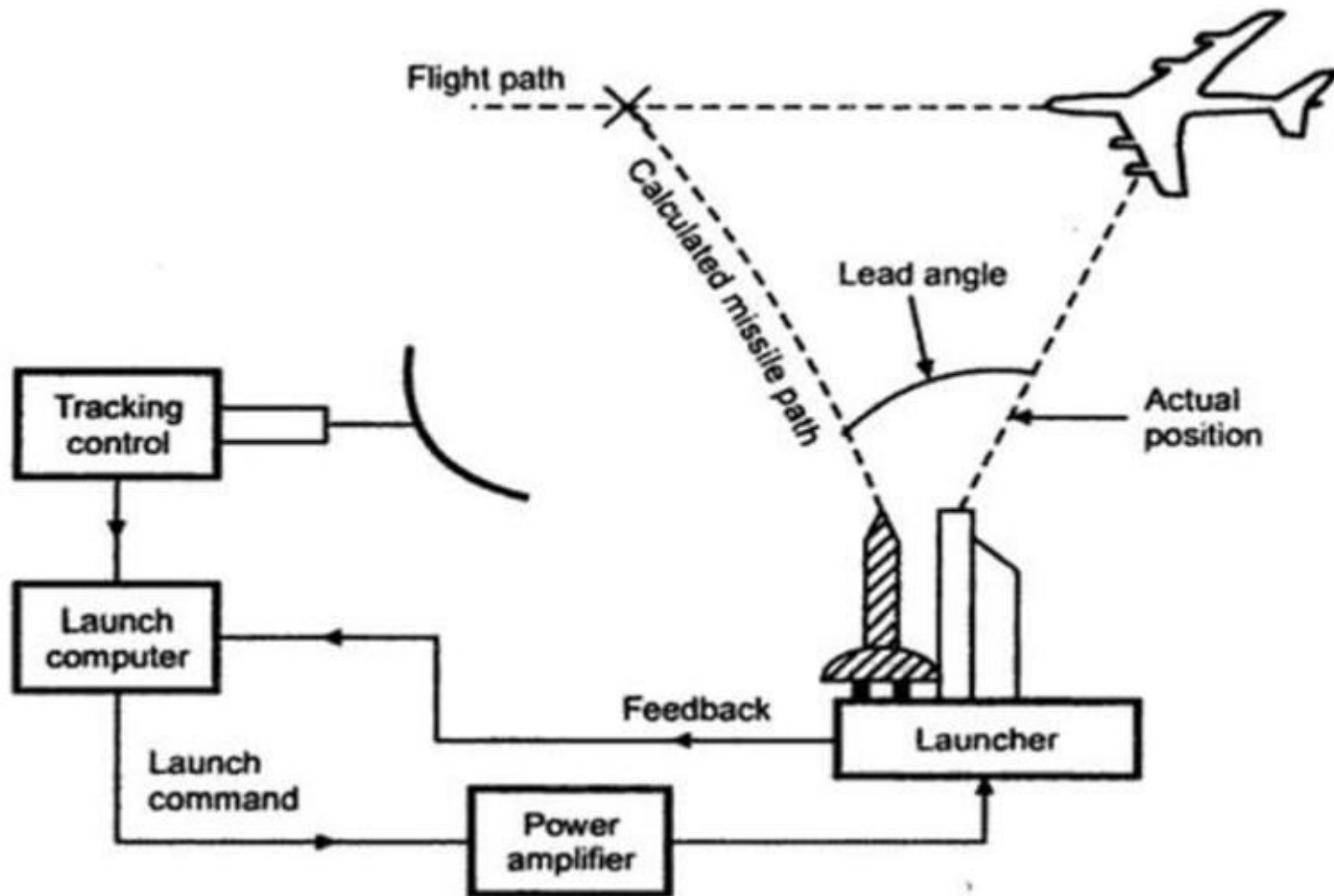

Missile launching system.

## Cont. ...

### ❖ Comparison between open loop and closed loop systems

Point of Difference	Open loop control system	Closed loop control system
<b>Definition</b>	No change in input with change in output	Change in output affects input
<b>Feedback loop</b>	Does not require feedback path element.	Requires feedback path element.
<b>Error Correction</b>	Not possible	Possible
<b>Construction</b>	It is simple and economical.	It is complex and costlier.

## Cont. ...

Point of Difference	Open loop control system	Closed loop control system
Sensitivity to noise	Highly sensitive	Less sensitive
Performance to operating conditions	<ul style="list-style-type: none"><li>• Its operation is degraded if non linearity is present</li><li>• Dependent on operating condition.</li></ul>	<ul style="list-style-type: none"><li>• Its operation is not independent on operating conditions.</li></ul>
Stability	It is more stable	It is less stable
Accuracy	<ul style="list-style-type: none"><li>• Has poor accuracy.</li><li>• Depends on calibration</li></ul>	<ul style="list-style-type: none"><li>• Has better accuracy.</li><li>• Accurate because of feedback.</li></ul>
Response	Has slow response.	Has fast response.