

1

Introduction to Switching Systems

1.1 INTRODUCTION

Telecommunication networks carry information signals among entities, which are geographically far apart. An entity may be a computer or human being, a facsimile machine, a teleprinter, a data terminal and so on.

With the rapidly growing traffic and untargeted growth of cyberspace, telecommunication becomes a fabric of our life. The future challenges are enormous as we anticipate rapid growth items of new services and number of users. What comes with the challenge is a genuine need for more advanced methodology supporting analysis and design of telecommunication architectures. Telecommunication has evaluated and growth at an explosive rate in recent years and will undoubtedly continue to do so.

The communication switching system enables the universal connectivity. The universal connectivity is realized when any entity in one part of the world can communicate with any other entity in another part of the world. In many ways telecommunication will acts as a substitute for the increasingly expensive physical transportation.

The telecommunication links and switching were mainly designed for voice communication. With the appropriate attachments/equipments, they can be used to transmit data. A modern society, therefore needs new facilities including very high bandwidth switched data networks, and large communication satellites with small, cheap earth antennas.

1.2. HISTORICAL DEVELOPMENT

By the early 1800's scientists had developed ways to generate and transmit electricity. In 1819, oersted discovered the relation between magnetism and electricity. Ampere, Faraday and others continued this work in 1820. In 1834, Gauss and Weber wired over the roofs of Gottingen to make a telegraph system. Samuel F.B. Morse's developed the first significant work in telecommunication. F.B. Morse developed code telegraphy in 1837. In 1844, a 40 mile telegraph line was setup between Baltimore and Washington by F.B. Morse. In 1845, Morse formed a telegraph company based on his technology. In 1849, the first slow telegraph printer link was setup. In 1874, Ban dot invented a "Multiplexes" system which enables up to six signal from telegraph machines to be transmitted together over the same line.

Elisha Gray and Alexander Graham Bell contributed significant works and filed paper related to telephony. The early stages of the development of telecommunication were due to A.G. Bell, G. Marconi and C.E. Shannon. In 1876, Bell invented a telephone system. In 1897 Marconi patented a wireless telephone system. Teletypewriter service was initiated in 1931.

In early days, a very simple exchanges whose control is provided by a human operator and the elements of the switch assemblies are plugs and sacks. With increase in demand of service, human operator exchange was replaced by the invention of range of electromechanical switching devices. Of all the electromechanical switching devices that become available over the years, the step-by-step switching system invented by Almon B. Strowger in 1892 is still quite popular. The next automatic electromechanical switching system was crossbar switching. First patent for crossbar device was granted in 1915 to J.N. Reynolds of wester Electric, USA. In 1919, two Swedish Engineers, Betulander and Palmgren got patent for crossbar switch. In 1938, AT & T laboratories in US introduced crossbar-switching system in the field.

The electromechanical switching systems have been replaced by computer controlled switching systems referred to as stored program control (SPC). In SPC, switching is controlled by software program. The first computer controlled switch

was introduced in 1960. Till 1965, computer controlled switching was used transistors and printed circuit technology. Since 1965 switching are based on microprocessors.

The use of computers to control the switching led to the designation “electronic” switching system (ESS) or Electronic automatic exchange (EAX). In 1970, first electronic switching system No. 1 ESS or No. 1 EAX was introduced. Digital electronic switching matrices were first introduced into the U.S. Public network in 1976 with AT & T’s No. 4 ESS digital toll switch. By the mid 1980’s the interoffice transmission environment has changed to almost exclusively digital.

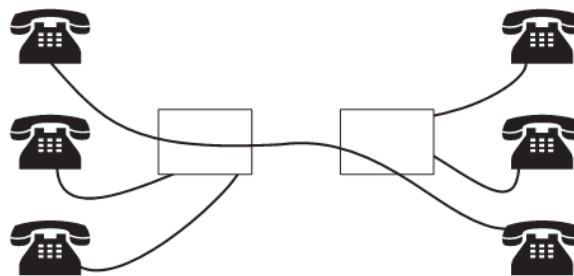

(a) Telephone network around 1890

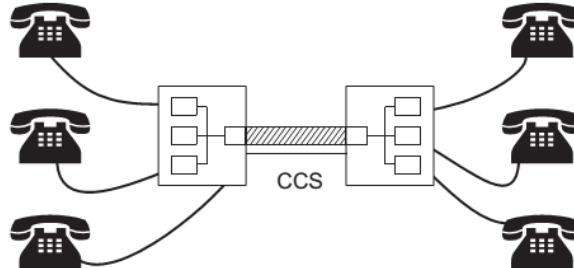

(b) Telephone network around 1988

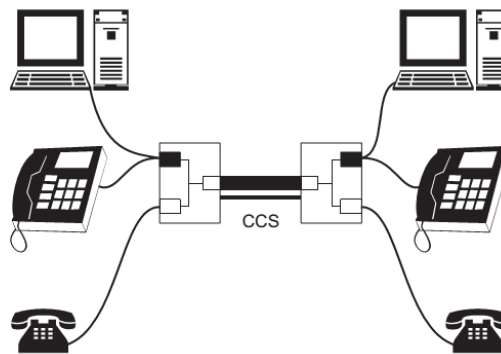

(c) Telephone network after 1990 with ISDN

Fig. 1.1 shows the various telephone networks.

1.3. SIGNAL CHARACTERISTICS

Telecommunication is mainly concerned with the transmission of messages between two distant points. The signal that contains the messages is usually converted into electrical waves before transmission. Our voice is an analog signal which has amplitude and frequency characteristic.

Voice frequencies.The range of frequencies used by a communication device determines the communication channel, communicating devices, bandwidth or information carrying capacity. The most commonly used parameter that characterizes an electrical signal is its bandwidth of analog signal or bit rate if it is a digital signal. In telephone system, the frequencies it passes are restricted to between 300 to 3400 Hz. Thus the network bandwidth is 3100 Hz. The bandwidth and bit rate for various types of system are shown in Table 1.1.

<i>Type</i>	<i>Bandwidth</i>	<i>Bit Rate</i>
Telephone (speech)	300—3400 Hz	—
Music	50 Hz—16 kHz	—
Facsimile	40 kHz	—
Broadcast television	0—55 MHz	—
Personal communication	—	300 to 9600 bits/sec
E—Mail transmission	—	2400 to 9600 bits/sec
Digitized voice phone call	—	6400 bits/sec
Digital audio	—	1 to 2 M bits/sec
Compressed video	—	2 to 10 M bits/sec
Document imaging	—	10 to 100 M bits/sec
Full motion video	—	1 to 2 G bits/sec

Table 1.1. Bandwidth requirements of various applications

Speech spectrum.The telephone channel over which we wish to send data are designed to transmit electrical oscillations (microphone converts sound into equivalent number of electrical oscillation) of voice. Fig. 1.2 is described as a speech spectrum diagram. It illustrates human speech strength variations at various frequencies. Most of the energy is concentrated between 300 Hz to 3400 Hz.

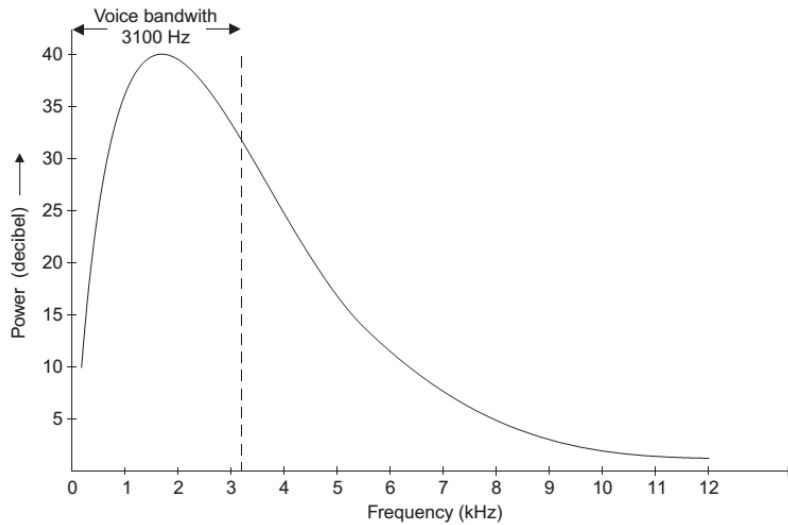

Fig. 1.2.Speed spectrum.

1.4. ELEMENTS OF COMMUNICATION SWITCHING SYSTEM

The purpose of a telecommunication switching system is to provide the means to pass information from any terminal device to any other terminal device selected by the originator.

Telecommunication system can be divided into four main parts. They are

1. End system or Instruments
2. Transmission system
3. Switching system
4. Signaling.

End Systems or Instruments:

The end system or instruments are a transmitter or receiver that are responsible for sending information or decoding or inverting received information or message into an intelligible message. End systems in the telephone network have evolved from analog telephones to digital handsets and cellular phones. However, endless arrays of other devices are being attached to telephone lines, including computer terminals used for data transmission. Fig. 1.3 shows some of the end instruments.

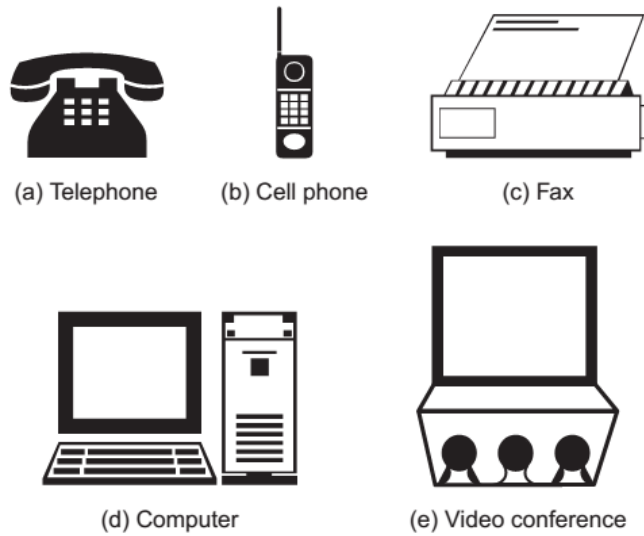

Fig. 1.3. Some of the end instruments.

Transmission System:

Signals generated by the end system or the instruments should be transported to the destination by some means. The transmission on links conveys the information and control signals between the terminals and switching centers. A transmission link can be characterized by its bandwidth, link attenuation and the propagation delay. To maintain signal quality, the signal must be regenerated after a certain distance.

In general a communication path between two distinct points can be setup by connecting a number of transmission lines in tandem. The transmission links include two-wire lines, coaxial cables, microwave radio, optical fibers and satellites. Functionally, the communication channels between switching systems are referred to as trunks. Fig. 1.4 shows the various possible transmission media.

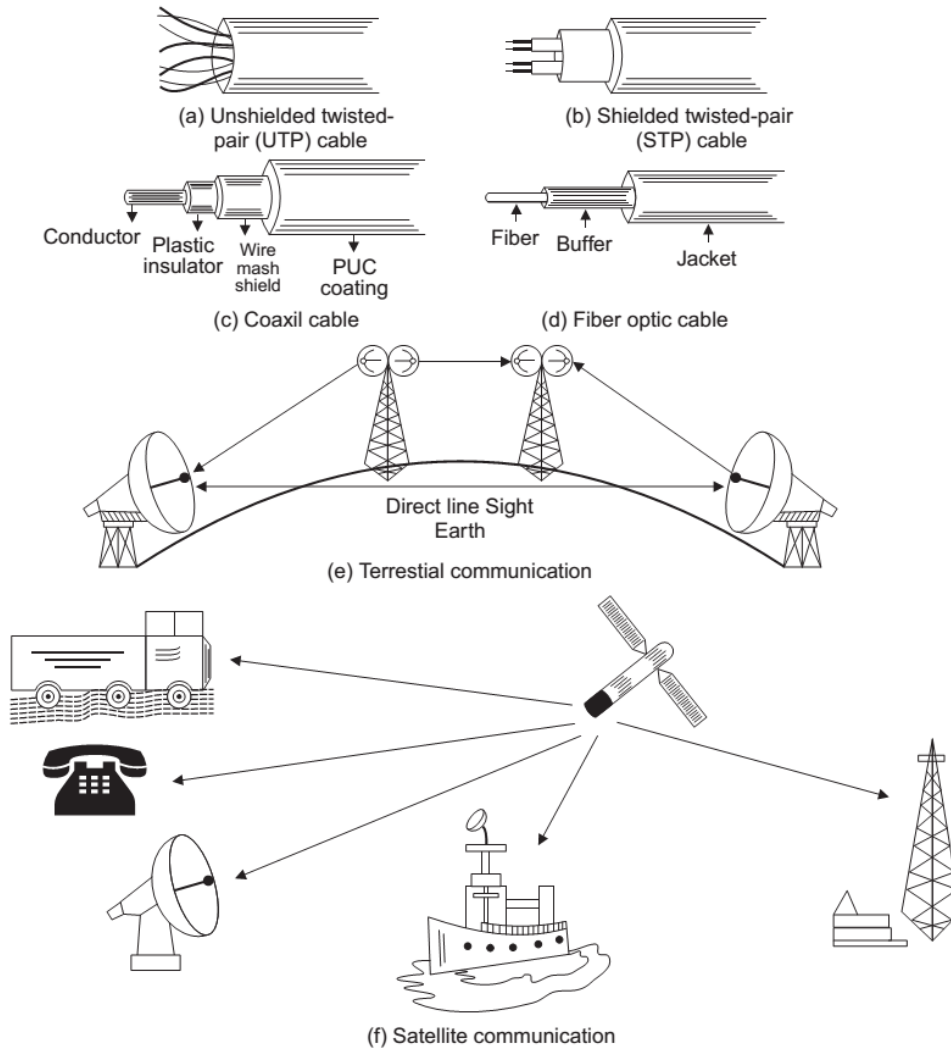

Fig. 1.4. Various transmission media.

Switching System. The switching centers receive the control signals, messages or conversations and forward them to the required destination, after necessary modification (link amplifications) if necessary. A switching system is a collection of switching elements arranged and controlled in such a way as to setup a communication path between any two distant points. A switching center of a telephone network comprising a switching network and its control and support equipment is called a central office.

In computer communication, the switching technique used is known as packet switching or message switch (store and forward switching). In telephone network the switching method used is called circuit switching. Some practical switching

system are step-by-step, cross barred relay system, digital switching systems, electronic switching system etc.

Signalling Systems. A signalling system in a data communication networks exchanges signalling information effectively between subscribers. The signalling systems are essential building blocks in providing the ultimate objective of a worldwide automatic telephone services standardized. Signalling provides the interface between different national systems. The introduction of signalling system was the big step in improving the PSTN.

The consultative committee on international telegraphy and telephony (CCITT) based in Geneva, recommended seven formats related to signalling. The first five formats related to Inband signalling and the last two in the category of common channel signalling. In In-band signalling, voice information and signalling information travel on common paths, where as in common channel signalling, they travel on separate paths.

1.5. CENTRALIZED SWITCHING SYSTEM

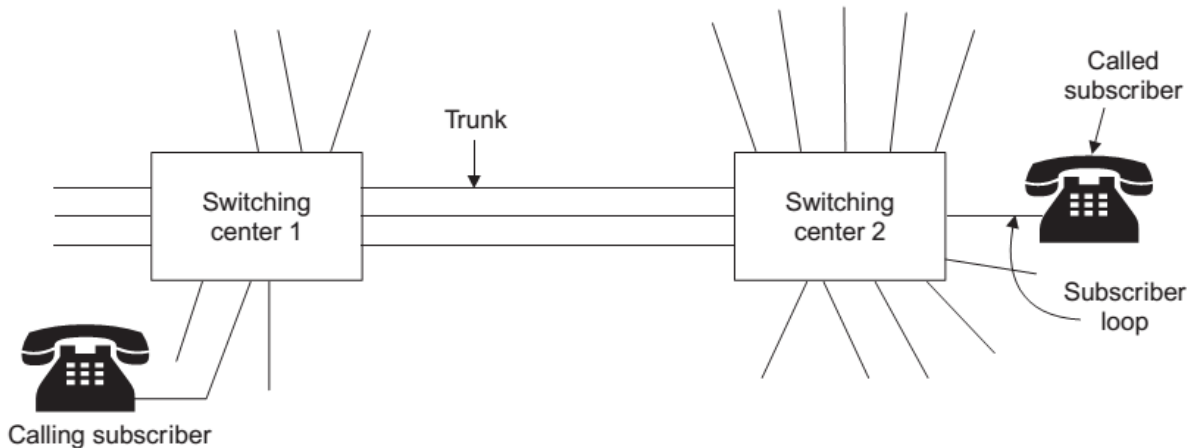

Fig. 1.6. Short distance centralised system.

Even though the increase in the number of switching centers lower the total transmission costs, the total switching cost tend to increase for two reasons.

1. The local centers become more complex because they must be able to decide on a suitable routing to another center.
2. Economy of scale is lost with an increased number of local centers because of additional numbers

Hierarchical system. Central offices may be interconnected by direct trunk groups or by intermediate office known as a tandem, toll or gateway office. The process of centralizing switching centers can occur at several levels leading to the hierarchical network. Typical interconnection of central office is shown in Fig. 1.7.

Star connection may be used where traffic intensity is less. Mesh connection are used when there are relatively high traffic levels between offices such as in metropolitan network.

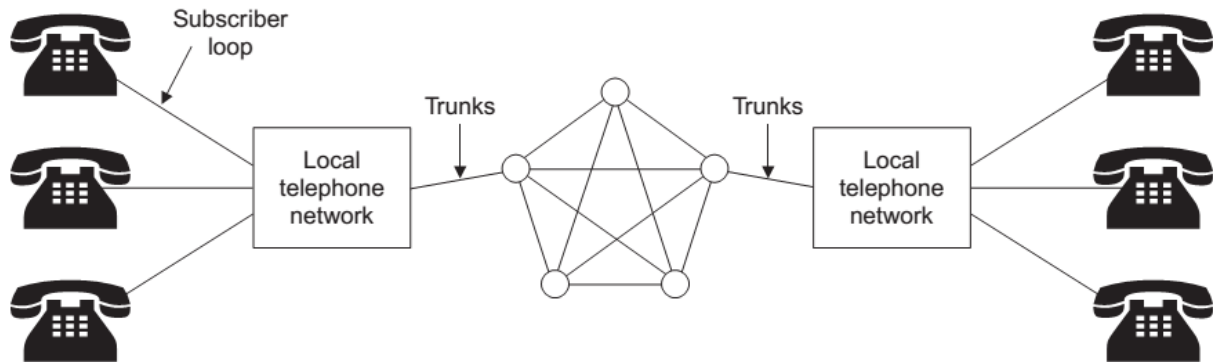

Fig. 1.7. Hierarchical network long level network (Star Connection)

Public Switched Telephone Networks

Public switched telephone network (PSTN) is an example of circuit-switched network. It's also known as Plain Old Telephone Service (POTS). The switching centres used for the switching are organised in different levels, namely: Regional offices (class 1), Section offices (class 2), primary offices (class 3), Toll offices (class 4) and finally End offices (class 5) as shown in Fig. 4.1.11. Level 1 is at the highest level and Level 5 is the lowest level. Subscribers or the customers are directly connected to these end offices. And each office is connected directly to a number of offices at a level below and mostly a single office at higher level.

Subscriber Telephones are connected, through Local Loops to end offices (or central offices). A small town may have only one end office, but large cities have several end offices. Many end offices are connected to one Toll office, which are connected to primary offices. Several primary offices are connected to a section office, which normally serves more than one state. All regional offices are connected using mesh topology. Accessing the switching station at the end offices is accomplished through dialling. In the past, telephone featured rotary or pulse

dialling, in which digital signals were sent to the end office for each dialled digit. This type of dialling was prone to errors due to inconsistency in humans during dialling. Presently, dialling is accomplished by Touch-Tone technique. In this method the user sends a small burst of frequency called dual tone, because it is a combination of two frequencies. This combination of frequencies sent depends on the row and column of the pressed pad.

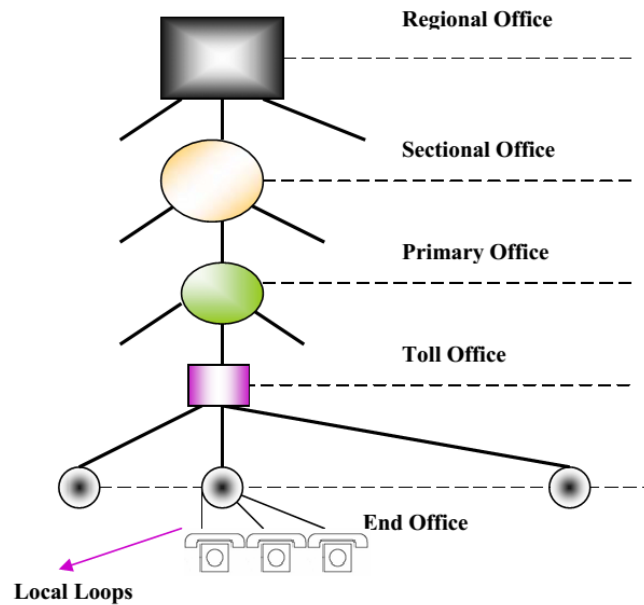

Figure 4.1.11 Basic organization of a Public Switched Telephone Network (PSTN)

The connections are multiplexed when have to send to a switching office, which is one level up. For example, Different connections will be multiplexed when they are to be forwarded from an end-office to Toll office. Figure 4.1.12 shows a typical medium distance telephone circuit

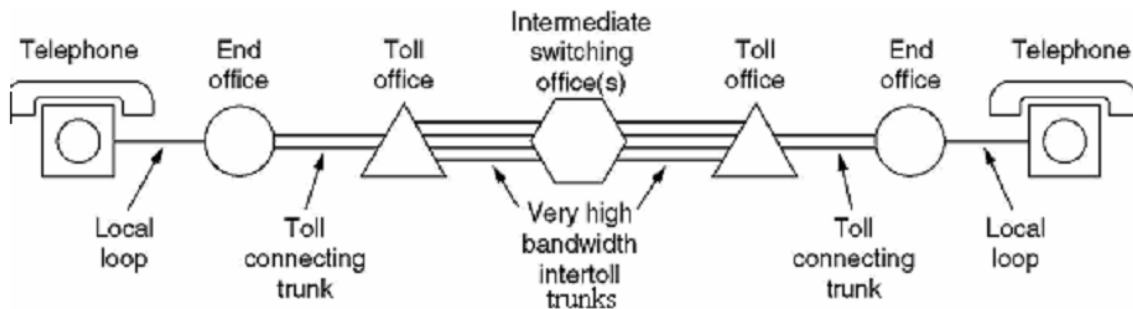

Figure 4.1.12 Typical medium distance telephone circuit

SIGNALING

The CCITT defines *signaling* as the “exchange of information specifically concerned with the establishment and control of connections and the transfer of user-to-user and management information in a telecommunication network.”

Signalling information can be send in two ways.

one is In-band signaling and other is

out-of-band signaling

In-band signaling and out-of-band signaling are illustrated in below Figure

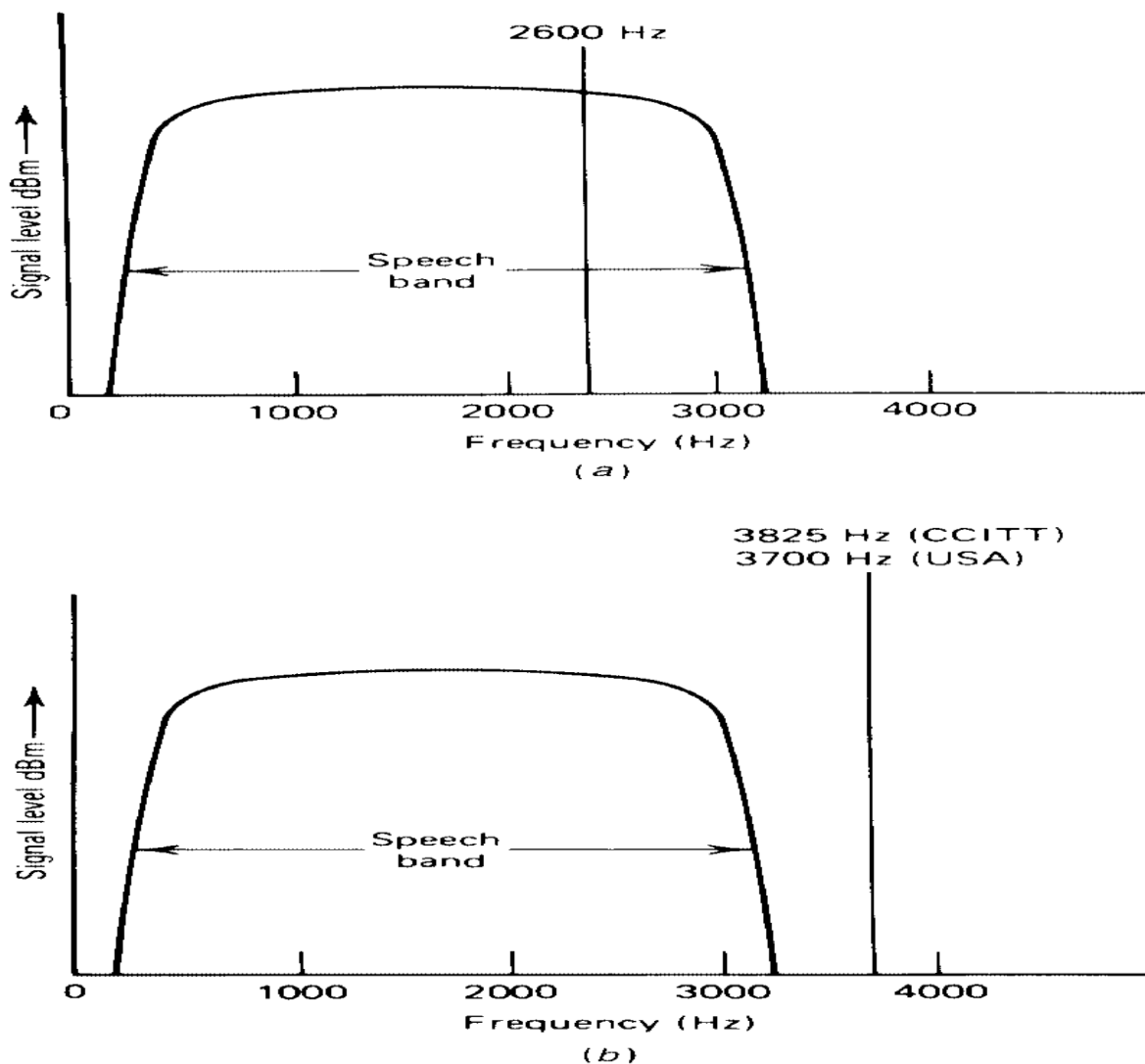

Figure signaling (a) in-band and (b) out-of-band.

Conventional signaling has evolved with the telephone network. Many of the techniques we deal with in this chapter are applicable to a telecommunication network which is principally involved with telephone calls. With telephony, signaling is broken down in three functional areas:

1. Supervisory;
2. Address; and
3. Call progress audible-visual.

DEFINING THE FUNCTIONAL AREAS

Supervisory Signaling

Supervisory signaling provides information on line or circuit condition. It informs a switch whether a circuit (internal to the switch) or a trunk (external to the switch) is busy or idle; when a called party is off-hook or on-hook, and when a calling party is on-hook or off-hook.

Supervisory information (status) must be maintained end-to-end on a telephone call, whether voice, data, or facsimile is being transported. It is necessary to know when a calling subscriber lifts her/his telephone off-hook, thereby requesting service. It is equally important that we know when the called subscriber answers (i.e., lifts the telephone off-hook) because that is when we may start metering the call to establish charges. It is also important to know when the calling and called subscribers return their telephones to the on-hook condition. That is when charges stop, and the intervening trunks comprising the talk path as well as the switching points are then rendered idle for use by another pair of subscribers. During the period of occupancy of a speech path end to end, we must know that this particular path is busy (i.e., it is occupied) so no other call attempt can seize it.

Address Signaling

Address signaling directs and routes a telephone call to the called subscriber. It originates as dialed digits or activated push-buttons from a calling subscriber. The local switch accepts these digits and, by using the information contained in the digits, directs the call to the called subscriber. If more than one switch is involved in the call setup, signaling is required between switches (both address and supervisory). Address signaling between switches is called *interregister signaling*.

Call Progress—Audible-Visual

This type of signaling we categorize in the *forward direction* and in the *backward direction*.

In the forward direction there is *alerting*. This provides some sort of audible-visual means of informing the called subscriber that there is a telephone call waiting. This is often done by ringing a telephone's bell. A buzzer, chime, or light may also be used for alerting.

The remainder of the techniques we will discuss are used in the backward direction. Among these are audible tones or voice announcements that will inform the calling subscriber of the following:

1. *Ringback*. This tells the calling subscriber that the distant telephone is ringing.
2. *Busyback*. This tells the calling subscriber that the called line is busy.
3. *ATB—All Trunks Busy*. There is congestion on the routing. Sometimes a recorded voice announcement is used here.
4. *Loud warble on telephone instrument—Timeout*. This occurs when a telephone instrument has been left off-hook unintentionally.

Multiplexing

It has been observed that most of the individual data-communicating devices typically require modest data rate. But, communication media usually have much higher bandwidth. As a consequence, two communicating stations do not utilize the full capacity of a data link. Moreover, when many nodes compete to access the network, some efficient techniques for utilizing the data link are very essential. When the bandwidth of a medium is greater than individual signals to be transmitted through the channel, a medium can be shared by more than one channel of signals. The process of making the most effective use of the available channel capacity is called Multiplexing. For efficiency, the channel capacity can be shared among a number of communicating stations just like a large water pipe can carry water to several separate houses at once. Most common use of multiplexing is in long-haul communication using coaxial cable, microwave and optical fibre.

Figure 2.7.1 depicts the functioning of multiplexing functions in general. The multiplexer is connected to the demultiplexer by a single data link. The multiplexer combines (multiplexes) data from these 'n' input lines and transmits them through the high capacity data link, which is being demultiplexed at the other end and is delivered to the appropriate output lines. Thus, Multiplexing can also be defined as a technique that allows simultaneous transmission of multiple signals across a single data link.

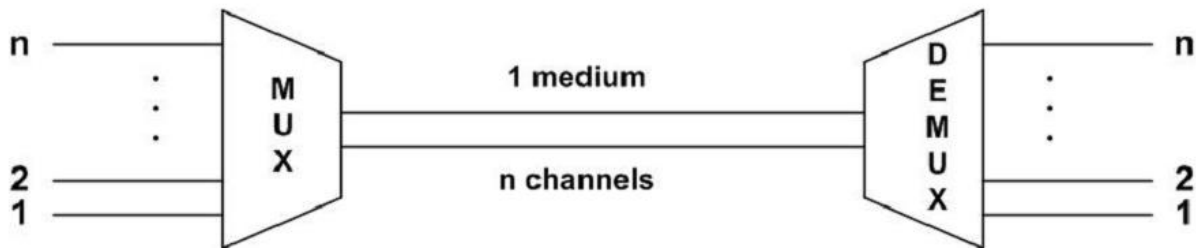

Figure 2.7.1 Basic concept of multiplexing

Multiplexing techniques can be categorized into the following three types:

- **Frequency-division multiplexing (FDM):** It is most popular and is used extensively in radio and TV transmission. Here the frequency spectrum is divided into several logical channels, giving each user exclusive possession of a particular frequency band.
- **Wavelength-Division Multiplexing (WDM):** Wavelength-division multiplexing (WDM) is conceptually same as the FDM, except that the multiplexing and de multiplexing involves light signals transmitted through fibre -optic channels.
- **Time-division Multiplexing (TDM):** It is also called synchronous TDM, which is commonly used for multiplexing digitized voice stream. The users take turns using the entire channel for short burst of time.
- **Statistical TDM:** This is also called asynchronous TDM, which simply improves on the efficiency of synchronous TDM.

In the following sections these techniques have been considered in detail.

Frequency-Division Multiplexing (FDM)

In frequency division multiplexing, the available bandwidth of a single physical medium is subdivided into several independent frequency channels. Independent message signals are translated into different frequency bands using modulation techniques, which are combined by a linear summing circuit in the multiplexer, to a composite signal. The resulting signal is then transmitted along the single channel by electromagnetic means as shown in Fig. 2.7.2. Basic approach is to divide the available bandwidth of a single physical medium into a number of smaller, independent frequency channels. Using modulation, independent message signals are translated into different frequency bands. All the modulated signals are combined in a linear summing circuit to form a composite signal for transmission. The carriers used to modulate the individual message signals are called sub-carriers, shown as f_1, f_2, \dots, f_n in Fig. 2.7.3 (a).



Figure 2.7.2 Basic concept of FDM

At the receiving end the signal is applied to a bank of band-pass filters, which separates individual frequency channels. The band pass filter outputs are then demodulated and distributed to different output channels as shown in Fig. 2.7.3(b).

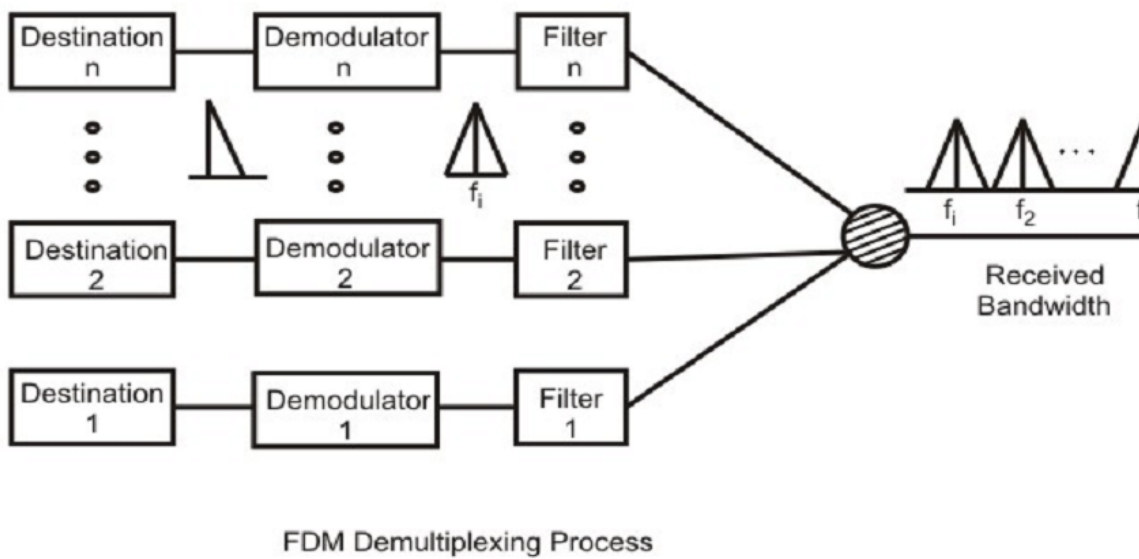
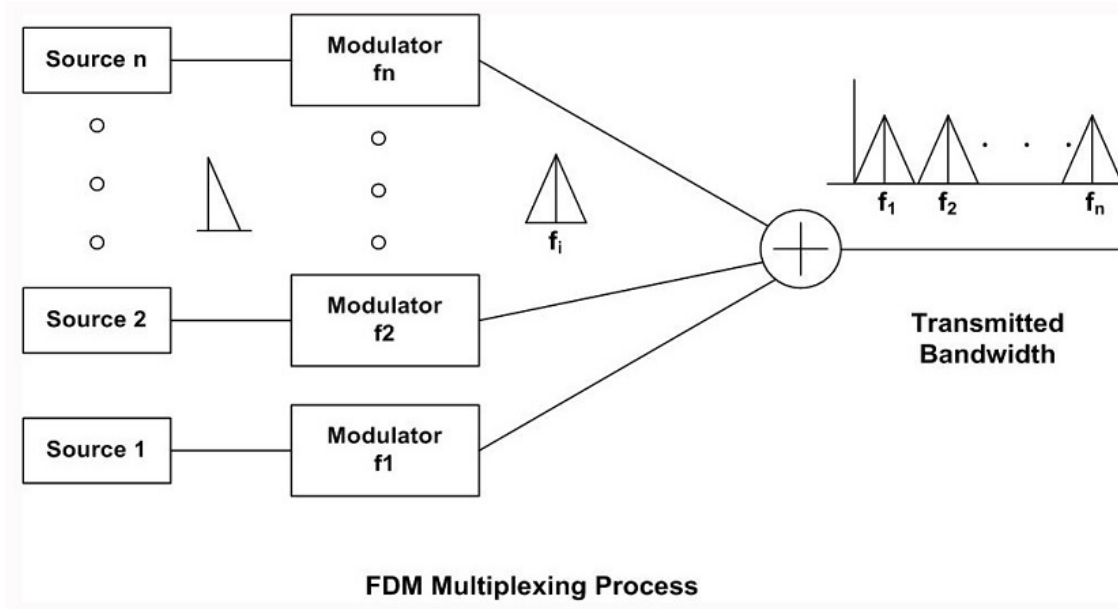

Figure 2.7.3 (a) FDM multiplexing process, (b) FDM de multiplexing process

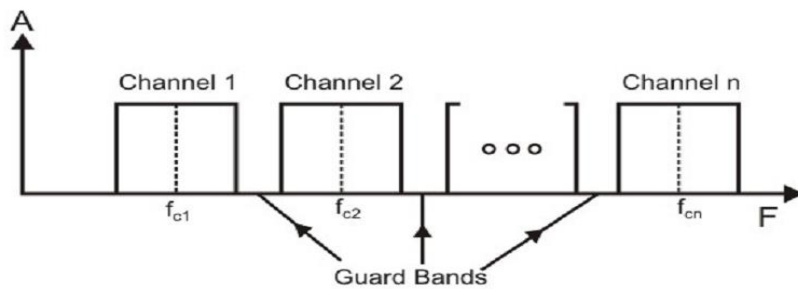

Figure 2.7.4 Use of guard bands in FDM

If the channels are very close to one other, it leads to inter-channel cross talk. Channels must be separated by strips of unused bandwidth to prevent inter-channel cross talk. These unused channels between each successive channel are known as guard bands as shown in Fig. 2.7.4.

FDM are commonly used in radio broadcasts and TV networks. Since, the frequency band used for voice transmission in a telephone network is 4000 Hz, for a particular cable of 48 KHz bandwidth, in the 70 to 108 KHz range, twelve separate 4 KHz sub channels could be used for transmitting twelve different messages simultaneously. Each radio and TV station, in a certain broadcast area, is allotted a specific broadcast frequency, so that independent channels can be sent simultaneously in different broadcast area. For example, the AM radio uses 540 to 1600 KHz frequency bands while the FM radio uses 88 to 108 MHz frequency bands.

2.7.3 Wavelength-Division Multiplexing

Wavelength-division multiplexing (WDM) is conceptually same as the FDM, except that the multiplexing and de multiplexing involves light signals transmitted through fibre -optic channels. The idea is the same: we are combining different frequency signals. However, the difference is that the frequencies are very high. It is designed to utilize the high data rate capability of fibre-optic cable. Very narrow band of light signal from different source are combined to make a wider band of light. At the receiver the signals are separated with the help of a de multiplexer as shown in Fig. 2.7.5.

Multiplexing and de multiplexing of light signals can be done with the help of a prism as shown in Fig. 2.7.6. From the basic knowledge of physics we know that light signal is bent by different amount based on the angle of incidence and wavelength of light as shown by different colours in the figure. One prism performs the role of a multiplexer by combining lights having different frequencies from different sources. The composite signal can be transmitted through an optical fibre cable over long distances, if required. At the other end of the optical fibre cable the composite signal is applied to another prism to do the reverse operation, the function of a de multiplexer.

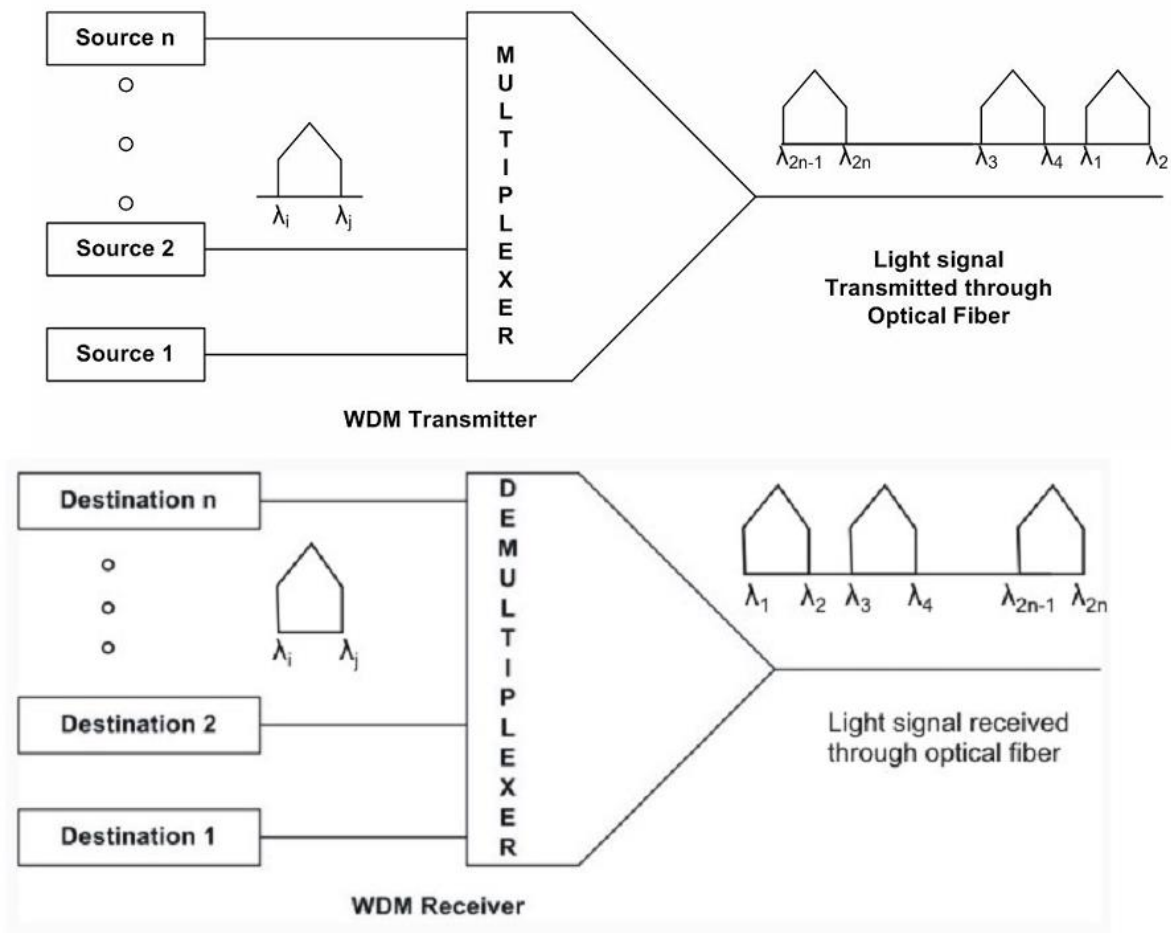

Figure 2.7.5 Basic WDM multiplexing and demultiplexing

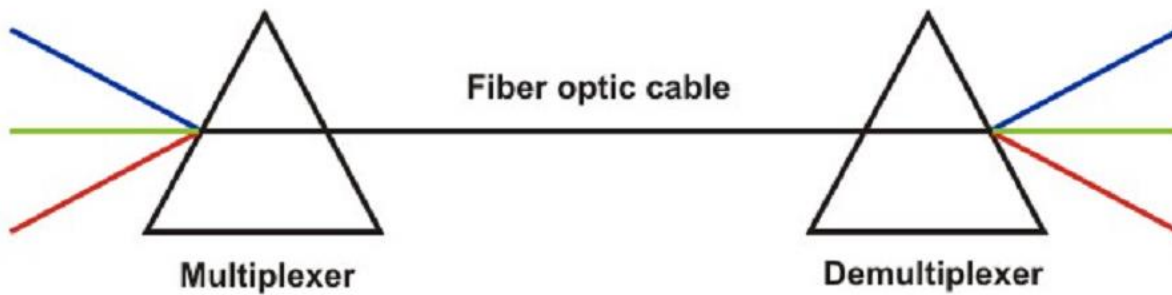

Figure 2.7.6 Multiplexing and de multiplexing of light signals with help of prisms

2.7.4 Time-Division Multiplexing (TDM)

In frequency division multiplexing, all signals operate at the same time with different frequencies, but in Time-division multiplexing all signals operate with same frequency at different times. This is a base band transmission system, where an electronic commutator sequentially samples all data source and combines them to form a composite base band signal, which travels through the media and is being de multiplexed into appropriate independent message signals by the corresponding commutator at the receiving end. The incoming data from each source are briefly buffered. Each buffer is typically one bit or one character in length. The buffers are scanned sequentially to form a composite data stream. The scan operation is sufficiently rapid so that each buffer is emptied before more data can arrive. Composite data rate must be at least equal to the sum of the individual data rates. The composite signal can be transmitted directly or through a modem. The multiplexing operation is shown in Fig. 2.7.7

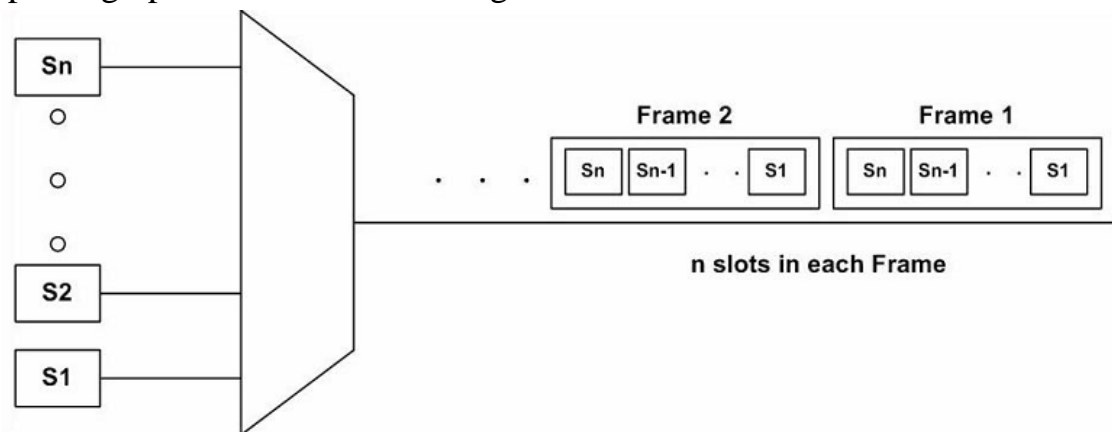

Figure 2.7.7 Time division multiplexing operation

As shown in the Fig 2.7.7 the composite signal has some dead space between the successive sampled pulses, which is essential to prevent inter channel cross talks. Along with the sampled pulses, one synchronizing pulse is sent in each cycle. These data pulses along with the control information form a frame. Each of these frames contain a cycle of time slots and in each frame, one or more slots are dedicated to each data source. The maximum bandwidth (data rate) of a TDM system should be at least equal to the same data rate of the sources.

Synchronous TDM is called synchronous mainly because each time slot is pre assigned to a fixed source. The time slots are transmitted irrespective of whether

the sources have any data to send or not. Hence, for the sake of simplicity of implementation, channel capacity is wasted. Although fixed assignment is used TDM, devices can handle sources of different data rates. This is done by assigning fewer slots per cycle to the slower input devices than the faster devices. Both multiplexing and de multiplexing operation for synchronous TDM are shown in Fig. 2.7.8.

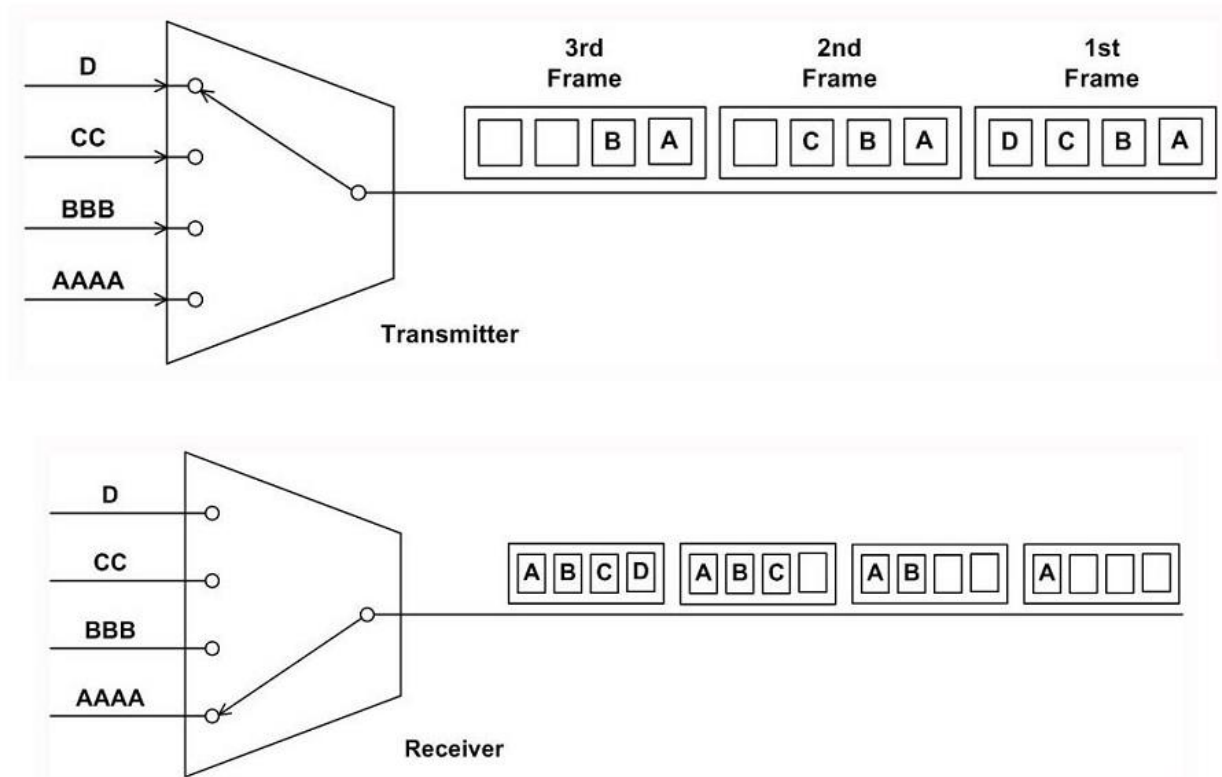

Figure 2.7.8 Multiplexing and de multiplexing in synchronous TDM

Statistical Time-division Multiplexing

One drawback of the TDM approach, as discussed earlier, is that many of the time slots in the frame are wasted. It is because, if a particular terminal has no data to transmit at particular instant of time, an empty time slot will be transmitted. An efficient alternative to this synchronous TDM is statistical TDM, also known as asynchronous TDM or Intelligent TDM. It dynamically allocates the time slots on demand to separate input channels, thus saving the channel capacity. As with Synchronous TDM, statistical multiplexers also have many I/O lines with a buffer

associated to each of them. During the input, the multiplexer scans the input buffers, collecting data until the frame is filled and send the frame. At the receiving end, the de multiplexer receives the frame and distributes the data to the appropriate buffers. The difference between synchronous TDM and asynchronous TDM is illustrated with the help of Fig. 2.7.9. It may be noted that many slots remain unutilised in case synchronous TDM, but the slots are fully utilized leading to smaller time for transmission and better utilization of bandwidth of the medium. In case of statistical TDM, the data in each slot must have an address part, which identifies the source of data. Since data arrive from and are distributed to I/O lines unpredictably, address information is required to assure proper delivery as shown in Fig. 2.7.10.. This leads to more overhead per slot. Relative addressing can be used to reduce overhead.

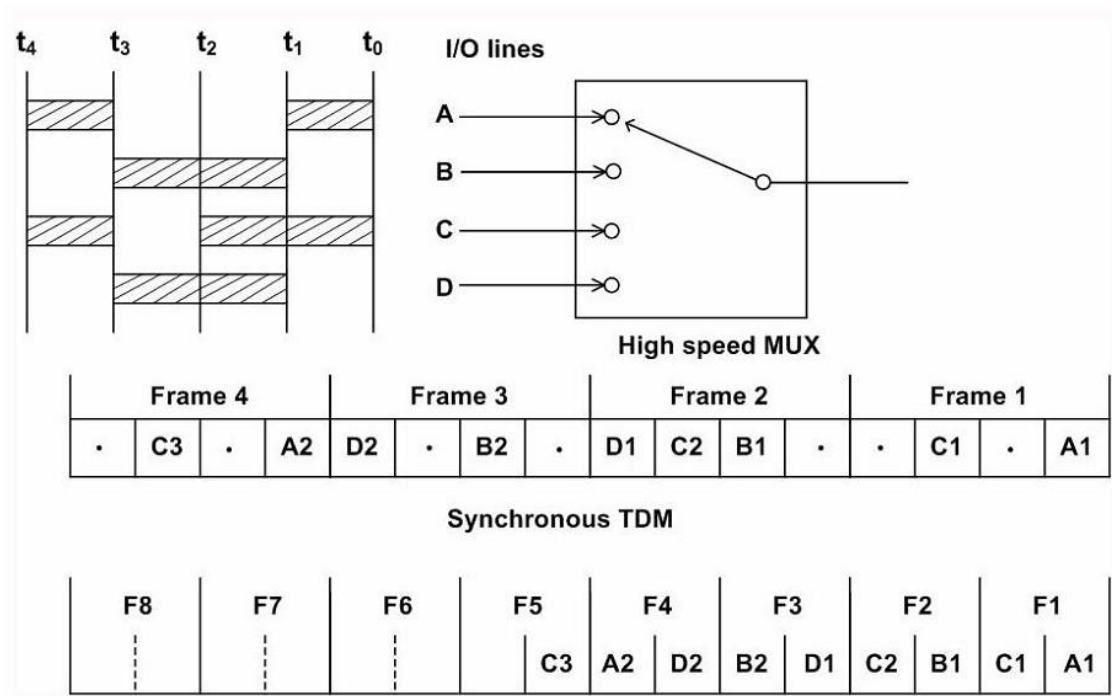

Figure 2.7.9 Synchronous versus asynchronous TDM

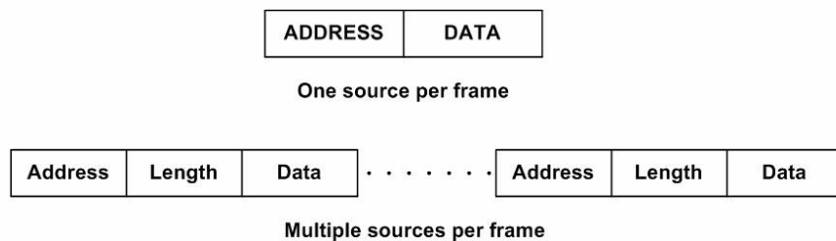

Figure 2.7.10 Address overhead in asynchronous TDM

Space-division switching

In Space-division switching, the paths in the circuit are separated with each other spatially, i.e. different ongoing connections, at a same instant of time, uses different switching paths, which are separated spatially. This was originally developed for the analog environment, and has been carried over to the digital domain. Some of the space switches are crossbar switches, Multi-stage switches (e.g. Omega Switches). A crossbar switch is shown in Fig. 4.1.4. Basic building block of the switch is a metallic crosspoint or semiconductor gate that can be enabled or disabled by a control unit.

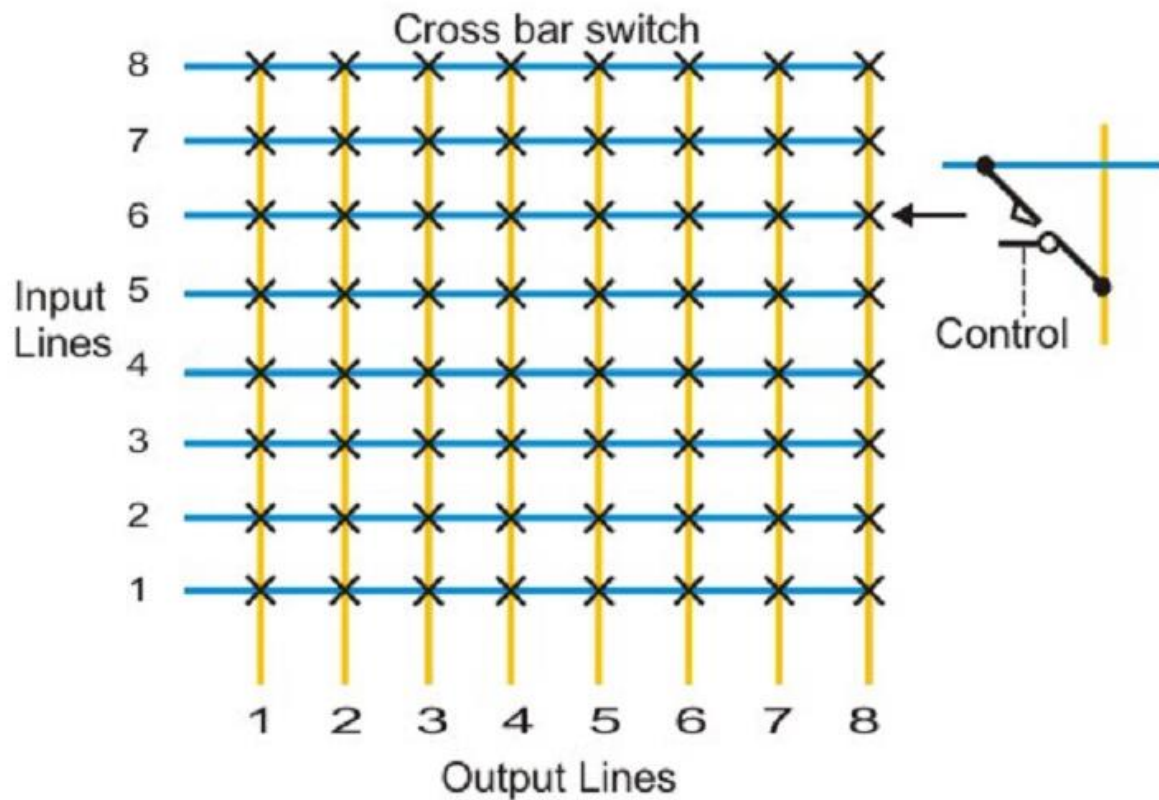

Figure 4.1.4 Schematic diagram of a crossbar switch

Example: Xilinx crossbar switch using FPGAs. It is based on reconfigurable routing infrastructure. It is a high-speed high capacity nonblocking type switch with sizes varying from 64X64 to 1024X1024 and data rate of 200 Mbps.

Limitations of crossbar switches are as follows:

- The number of crosspoints grows with the square of the number of attached stations.
- Costly for a large switch.

- The failure of a crosspoint prevents connection between the two devices whose lines intersect at that crosspoint.
- The crosspoints are inefficiently utilized.
- Only a small fraction of crosspoints are engaged even if all of the attached devices are active.

Some of the above problems can be overcome with the help of multistage space division switches. By splitting the crossbar switch into smaller units and interconnecting them, it is possible to build multistage switches with fewer crosspoints.

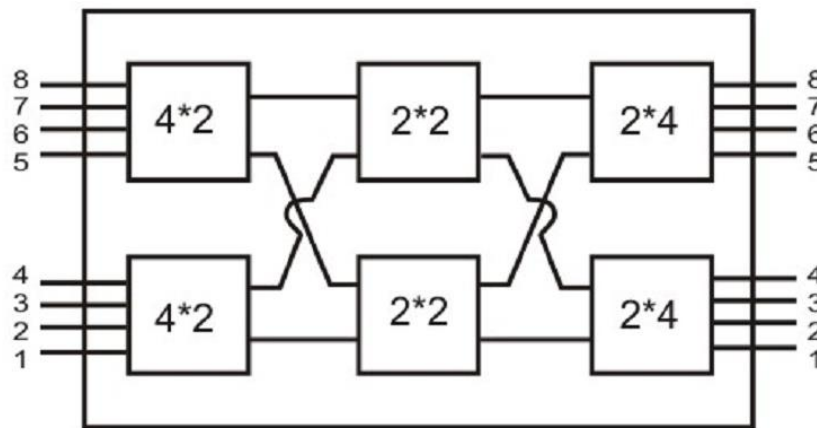

Figure 4.1.5 A three-stage space division switch



Figure 4.1.6 Block nature of the switch

Figure 4.1.5 shows a three-stage space division switch. In this case the number of crosspoints needed goes down from 64 to 40. There is more than one path through the network to connect two endpoints, thereby increasing reliability. Multistage switches may lead to blocking. The problem may be tackled by increasing the number or size of the intermediate switches, which also increases the cost. The blocking feature is illustrated in Fig. 4.1.6. As shown in Fig. 4.1.6, after setting up connections for 1-to-3 and 2-to-4, the switch cannot establish connections for 3-to-6 and 4-to-5.

Why Digital:

We have several advantages in digital compared to analog. Hence we shift from analog to digital. Following are the reasons why we are choosing digital

Easy of Multiplexing

Easy of Signalling

Use of Modern Technology

Integration of transmission and switching

Signal Regeneration by using repeaters

Performance monitorability

Accommodation of other services

Operability at low S/N Ratio

Easy of Encryption.